

Fitting instructions

Make: Mitsubishi

Outlander (Incl. PHEV); 2012->

Type: 5679

МАГАЗИН



ФАРКОПОВ

+7 (495) 6-693-693

www.magfarkop.ru

magfarkop@yandex.ru

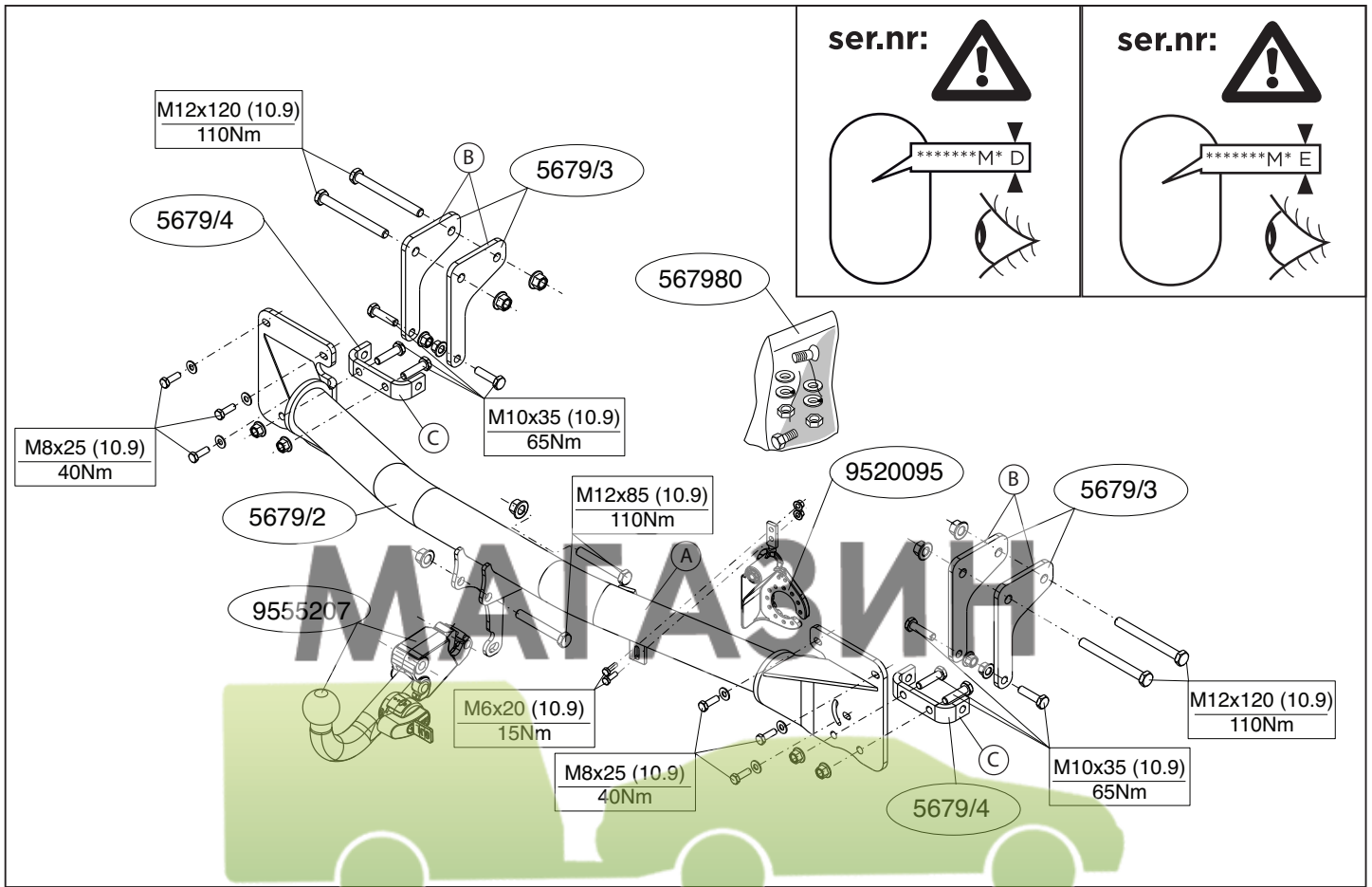

© 567970/31-10-2013/1

ФАРКОПОВ
+7 (495) 6-693-693

www.magfarkop.ru
magfarkop@yandex.ru

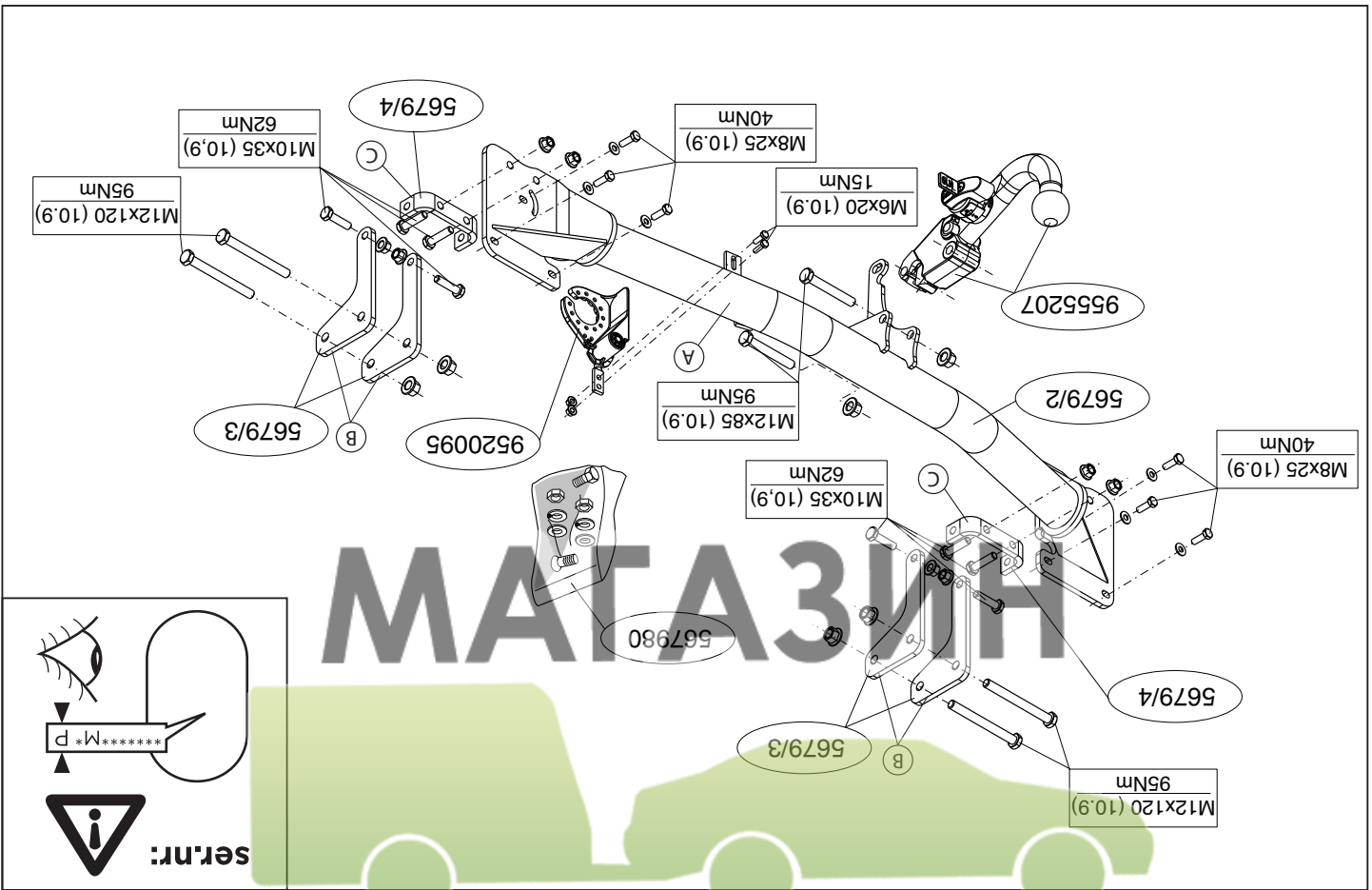

МАГАЗИН

ФАРКОПОВ

+7 (495) 6-693-693

www.magfarkop.ru

magfarkop@yandex.ru

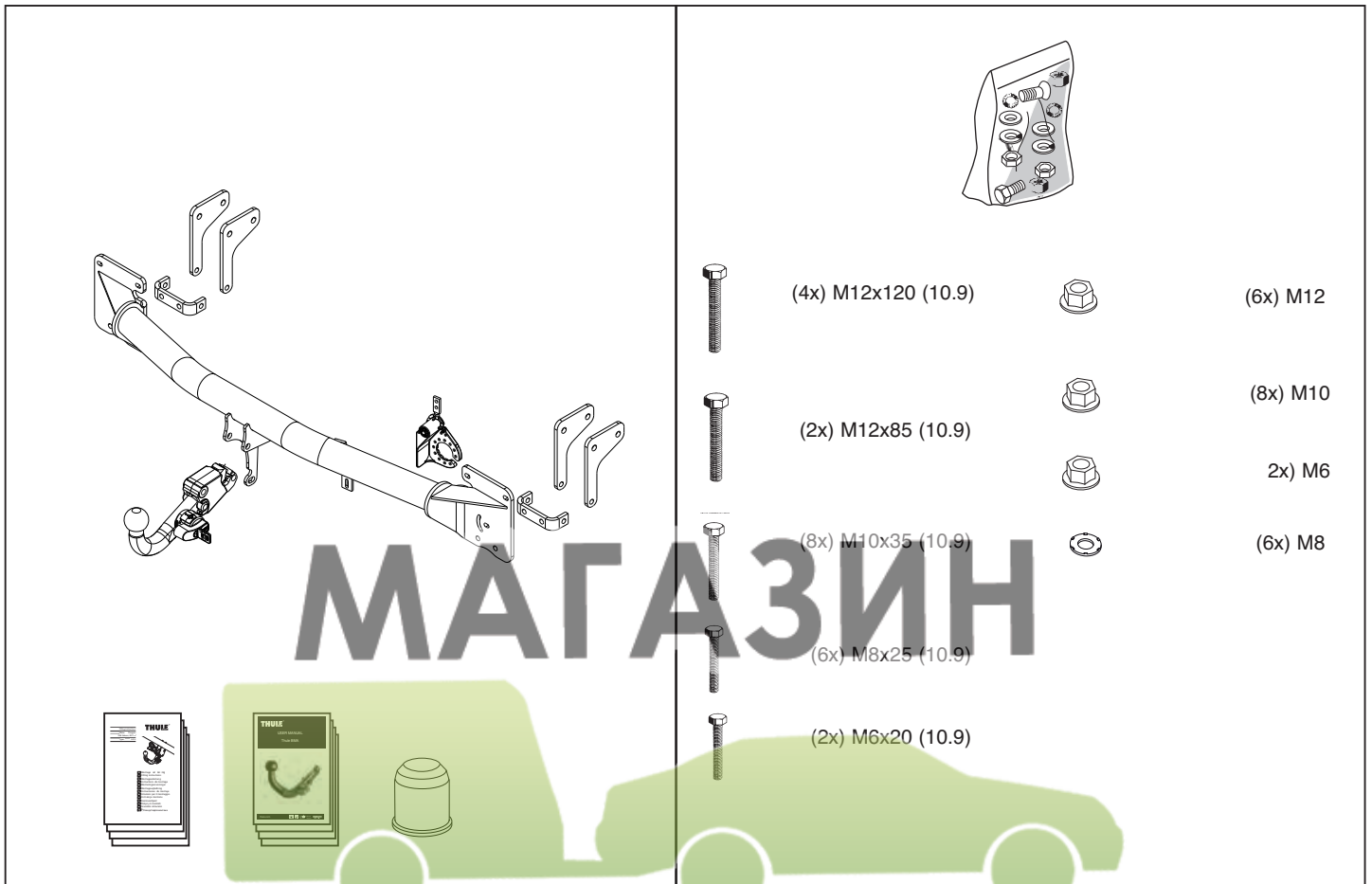

© 567970/31-10-2013/3

МАГАЗИН

ФАРКОПОВ

+7 (495) 6-693-693

www.magfarkop.ru
magfarkop@yandex.ru

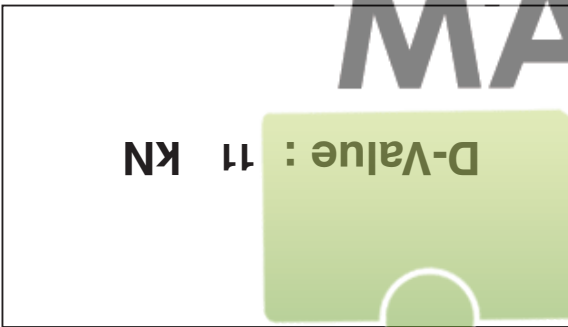
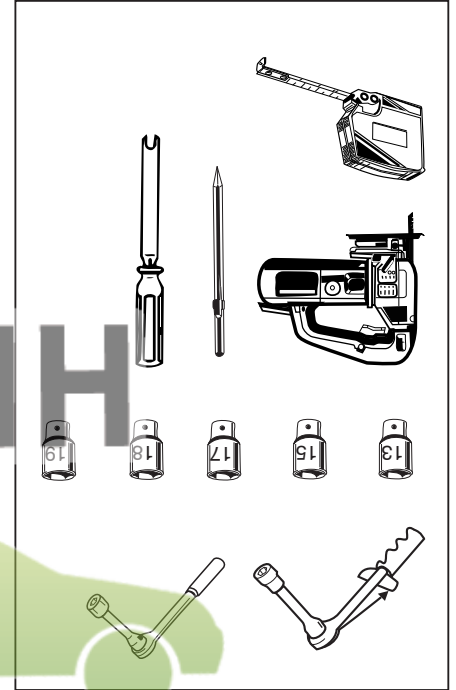
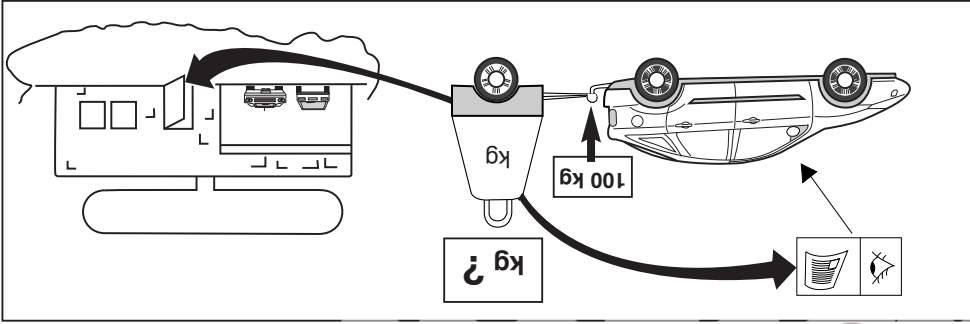
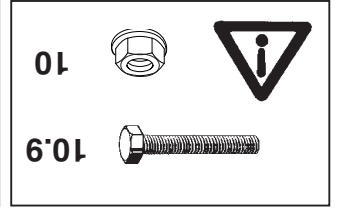
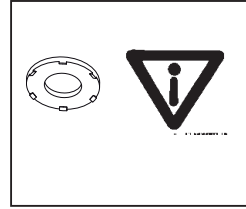
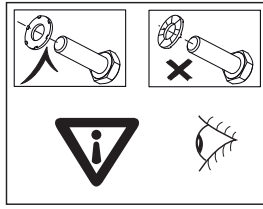
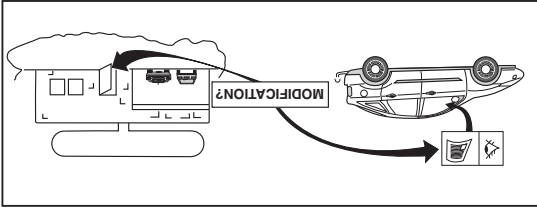

МАГАЗИН

ФАРКОПОВ

+7 (495) 6-693-693

www.magfarkop.ru
magfarkop@yandex.ru



NL.

* Thule is niet aansprakelijk voor de schade die het direct of indirect gevolg is van onjuiste montage, daaronder begrepen gebruik van niet-geschiedte gereedschappen en het gebruik van andere dan de voorgeschreven montagewijze en middelen, dan wel onjuiste interpretatie van dit onderhavig montagevoorschrift.

GB.

NOTE:

* **Should this installation process entail the cutting of the bumper – conformation MUST be obtained by the installation engineer of the customer’s acceptance prior to completion. Thule Towing Systems do not accept responsibility for any matters arising as a result of this miscommunication.**

All measurements are in mm!

* Thule is not liable for damage caused directly or indirectly by incorrect assembly, including the use of unsuitable tools, the use of other assembly methods and means than the ones outlined, and the incorrect interpretation of these assembly instructions.

D.

HINWEISE:

* Die für das Fahrzeug zugelassene Anhängelast ist den Fahrzeug Unterlagen zu entnehmen. Bei Änderungen des Fahrzeuggewichtes muß die höchstzulässige Anhängelast gegebenenfalls aus dem D-Wert nachgerechnet werden.

Auskunft hierüber kann Ihr Fachhändler oder der TÜV geben.

* Elektrische Anlage gemäß StVZO anbringen.

* Thule haftet nicht für Schäden, die als direkte oder indirekte Folge einer nicht ordnungsgemäßen Montage auftreten, darunter fallen auch die Benutzung von ungeeigneten Werkzeugen, andere als die vorgeschriebenen Montageverfahren und Montagemittel sowie eine fehlerhafte Interpretation der betreffenden Montageanweisung.

F.

* Thule décline toute responsabilité pour les dommages qui pourraient directement ou indirectement résulter d’un montage incorrect, y compris l’utilisation d’outils inappropriés et l’utilisation d’un mode d’emploi et de moyens autres que ceux prescrits, ou bien résulter d’une interprétation inexacte des présentes instructions de montage.

S.

* Thule är inte ansvariga för skada som orsakats direkt eller indirekt av felaktig montering, inklusive användning av olämpliga verktyg, andra monteringsmetoder och processer än de som beskrivs, samt felaktig tolkning av dessa monteringsinstruktioner.

DK.

* Thule er ikke ansvarlig for skade der direkte eller indirekte er forårsaget af forkert montage, herunder også iberegnet brug af forkert værktøj og anvendelse af anden montage metode og andre montage midler end de foreskrevne samt fejltolkning af den medfølgende montagevejledning.

E.

* Thule no se responsabiliza por daños causados, directa o indirectamente, por un montaje incorrecto, incluyendo el uso de herramientas inadecuadas, por el uso de métodos de montaje y medios distintos a los indicados y por la interpretación incorrecta de estas instrucciones de montaje.

I.

* Thule non può essere ritenuta responsabile per eventuali danni direttamente o indirettamente dovuti ad un errato montaggio, intendendo con ciò anche l’uso di attrezzi non idonei e l’uso di metodi e mezzi di montaggio diversi da quelli prescritti, nonché all’errata interpretazione delle seguenti istruzioni di montaggio.

PL.

* Firma Thule nie ponosi odpowiedzialności za straty poniesione pośrednio lub bezpośrednio na skutek niewłaściwego montażu, w tym użycia

© 567970/31-10-2013/5

МАГАСИИ ФАРКОПОВ

Dispositivo di traino tipo: 5679
Per autoveicoli: Mitsubishi Outlander (incl. PHEV); 2012->
Tipo funzionale: GF0

+7 (495) 6-693-693

Classe e tipo di attacco: A50-X
Omologazione: E11 55R-018570

Valore D: 11 kN

Carico Verticale max. S: 100 kg

Larghezza rimorchiabile per Caravan e T.A.T.S.: 2,45m vedere CARTA di CIRCOLAZIONE VEICOLO (motrice) + 70 cm = ..arrotondare ai 5 cm superiore (vedi D.M.28/05/85)

Massa rimorchiabile: vedi carta di circolazione dell’ autoveicolo

www.magfarkop.ru
magfarkop@yandex.ru

Per verificare l’idoneità del dispositivo di traino omologato a norma ECE/R55, all’installazione sulla vettura su cui si intende procedere al montaggio, compilare la seguente formula (se necessario declassare la massa rimorchiabile):

$$D = \frac{T \times C}{T + C} \times 0,00981 \leq 11 \text{ kN}$$

dove: T= Massa Complessiva Max. della motrice (in kg)
C= Massa Rimorchiabile Max. della motrice (in kg)

DA COMPILARE PER IL COLLAUDO

DICHIARAZIONE DI CORRETTO MONTAGGIO: la sottoscritta Ditta dichiara di aver montato in maniera corretta ed in conformi/ alle prescrizioni sia del costruttore del veicolo che del costruttore del dispositivo stesso il seguente dispositivo di attacco meccanico:

tipo:.....
Il dispositivo di attacco sopra indicato è stato installato su autoveicolo
modello:.....
targa:.....
Data:.....

TIMBRO e FIRMA

Si dichiara inoltre di aver informato l’utente del veicolo sull’USO e MANUTENZIONE del dispositivo stesso.

© 567970/31-10-2013/14

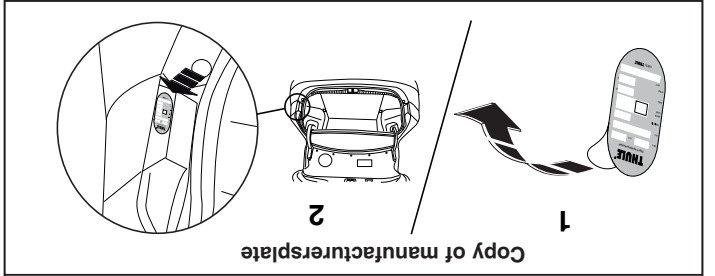
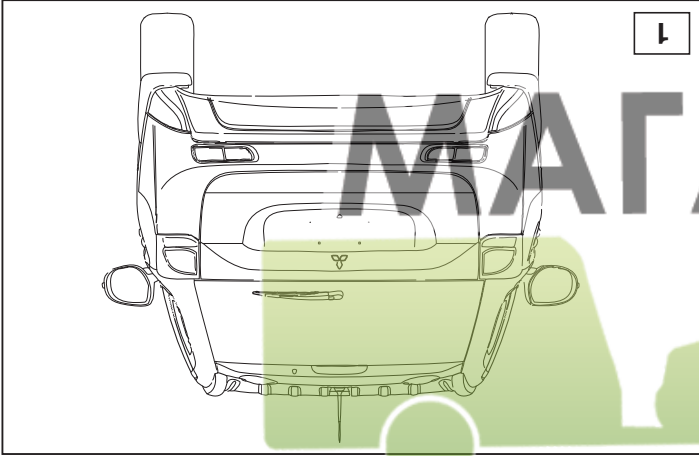
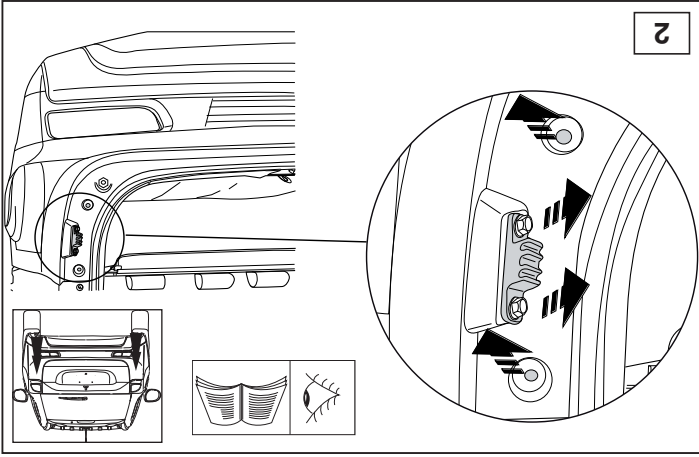

ниwärtschlych narzędzi i sposobow montazu niezgodnych z instrukcją
 oraz niezastosowanie się do treści instrukcji.
 SF: * Thule ei ole vastuussa violitumisesta, jōka on suoraan tai epäsuoraan aiheutunut vāärāstä asennuksesta samoin kuin sopimattomien työkālu-
 jen kāytōstā, muiden kuin ohjeissa mainittujen asennusmenetelmien tai
 vālinneiden kāytōstā sekā kyseisten asennusohjeiden vāärinlūkimista.
 CZ: * Společnost Thule neodpovídā za primě ani nepřimě škody zpūsobeně
 nespřāvnuou montāží, včetně použití nevhodných nástrojů, pozitií jiných
 metod montāže a prostředkū než uvedených a nesprāvny m pocho-
 pením tēchto pokynů k montāži.
 H: * A Thule nem vállal felelősséget a nem megfelelő szerelésből kőzvetlen
 vagy közvetett módon kővetkezō kārōkért. Ez vonatkozīk a nem meg-
 elōid szerzszerzők hasznālatāra, a leírattól eltérō módszerek és
 eszközōk alkalmazāsāra, valamint a szerelési útmutatō tēves érte-
 mezésére.
 RUS: * Фирма Thule не отвечает за ущерб, являющийся прямым или косвенным след-
 ствием неправильного монтажа, в том числе использования неподходящих
 инструментов и применения иного способа монтажа или других средств, чем
 предписано в инструкции, либо неправильного истолкования настоящей инструк-
 ции по монтажу.
 Copy of manufacturer's plate

ФАРКОПОВ

+7 (495) 6-693-693

www.magfarkop.ru
magfarkop@yandex.ru

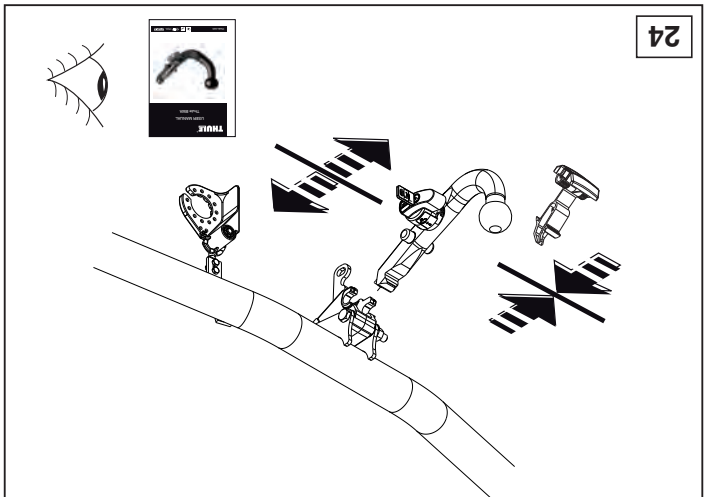
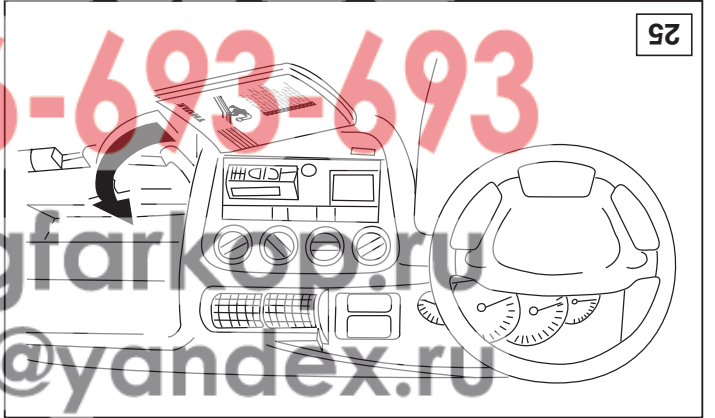

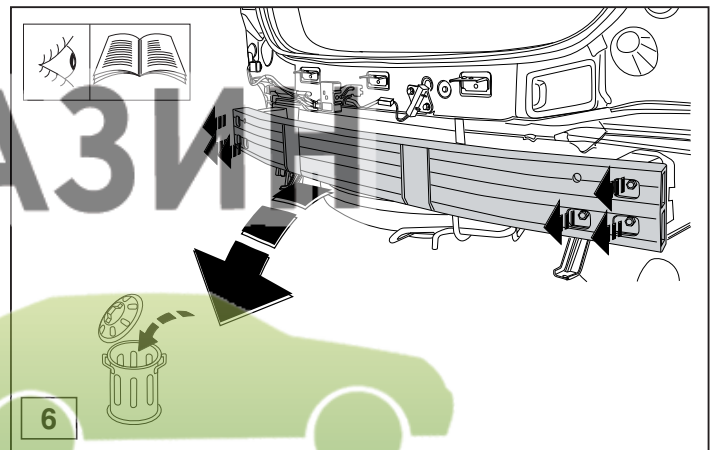
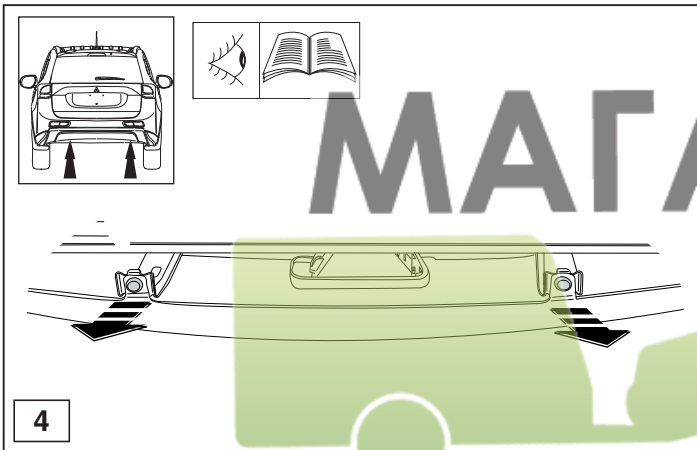
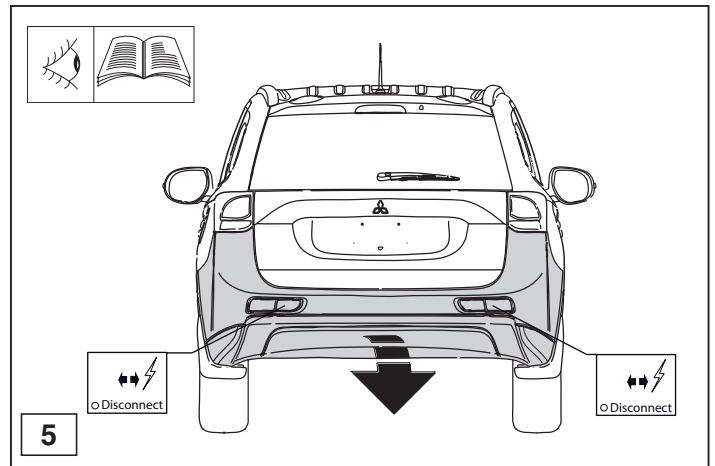
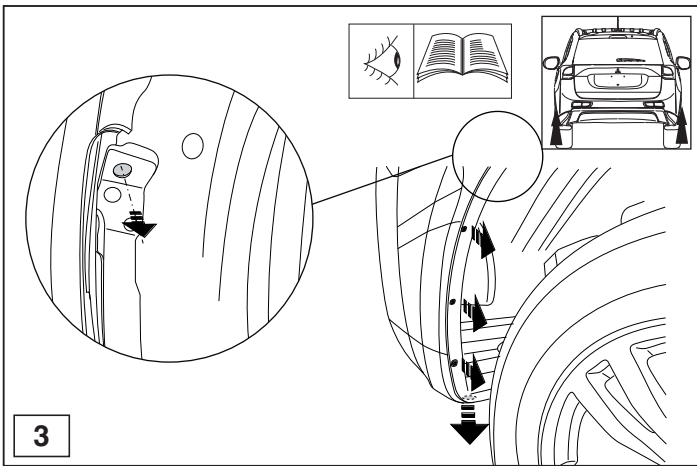

© 567970/31-10-2013/7

МАГАЗИН ФАРКОПОВ

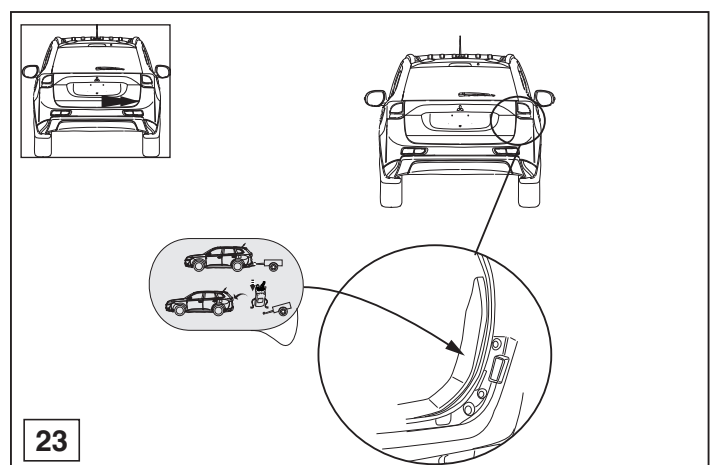
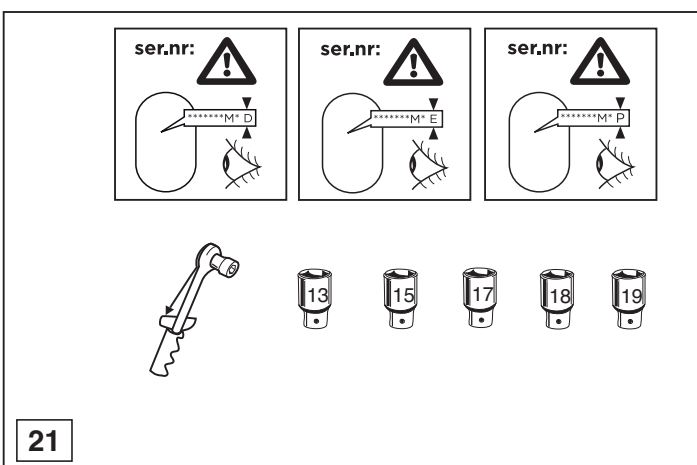
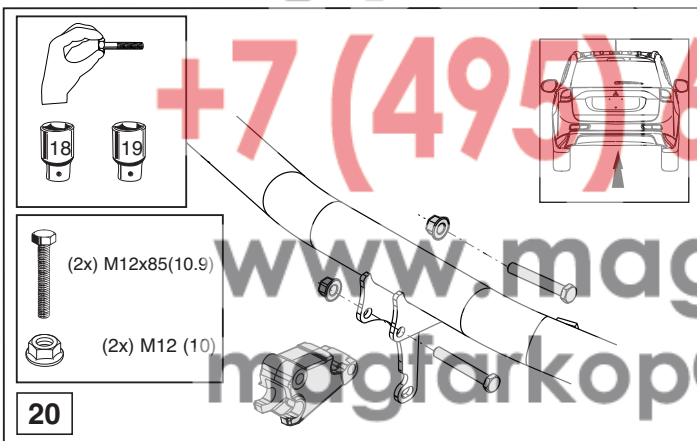

© 567970/31-10-2013/12

+7 (495) 6-693-693

www.magfarkop.ru
magfarkop@yandex.ru

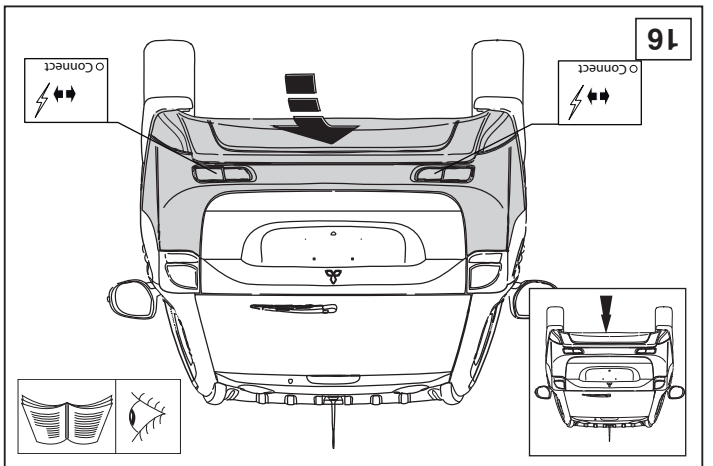
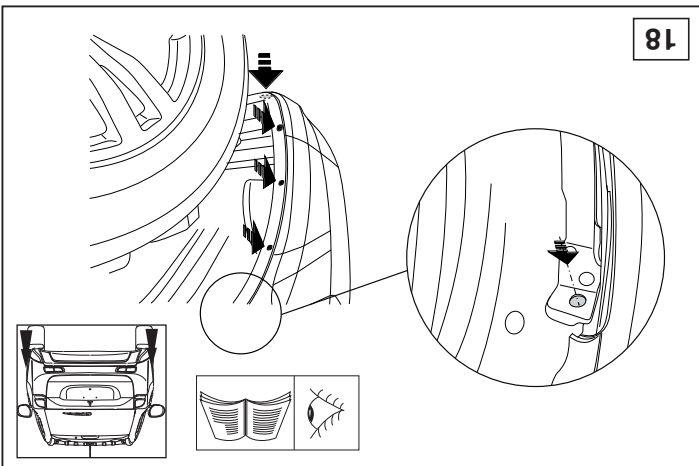
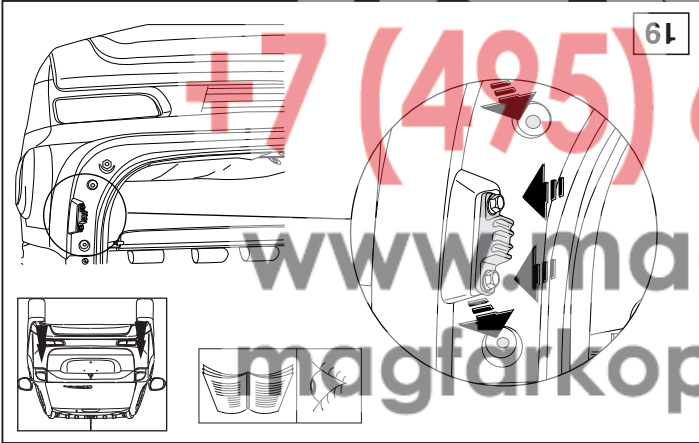
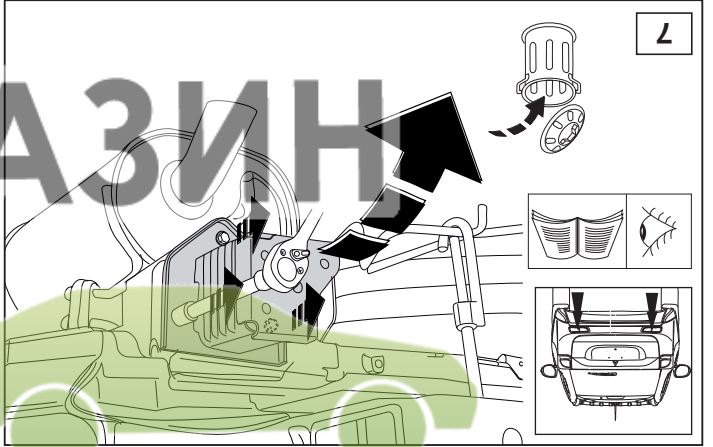
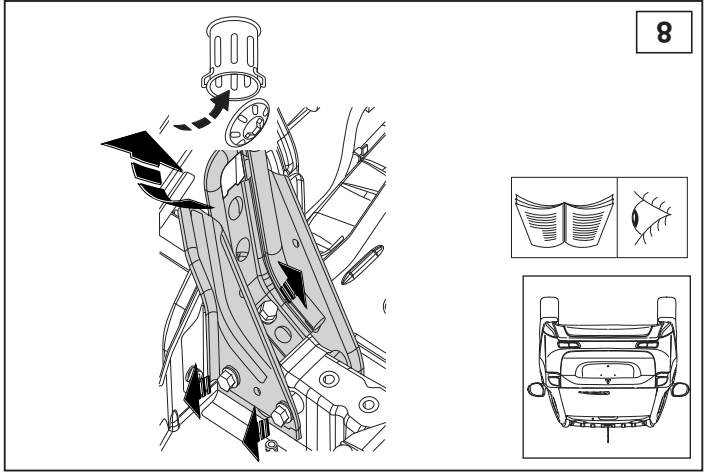
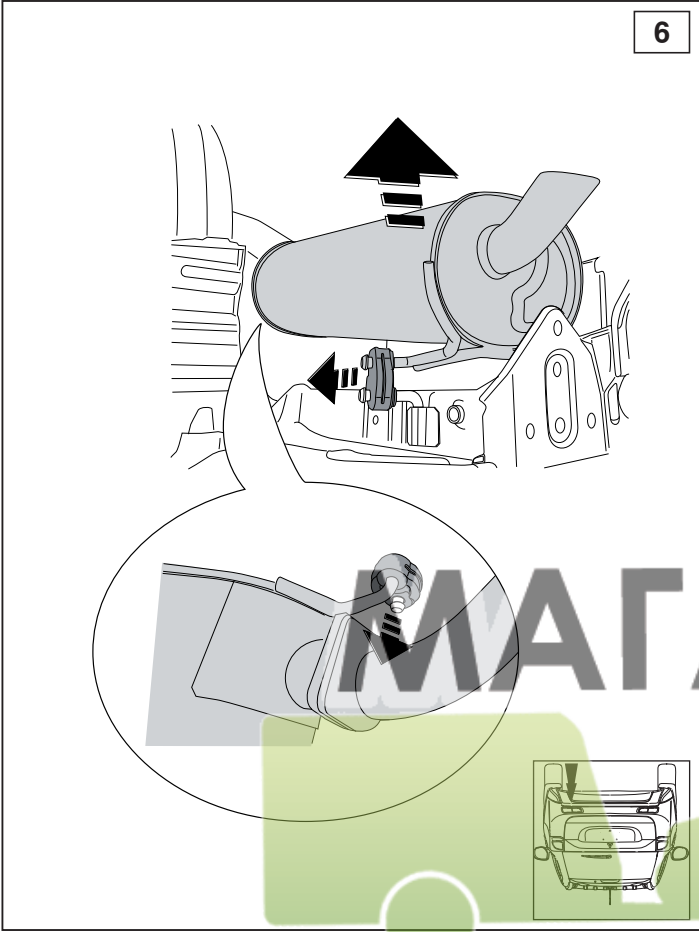

МАГАЗИН ФАРКОПОВ

+7 (495) 6-693-693

www.magfarkop.ru

magfarkop@yandex.ru

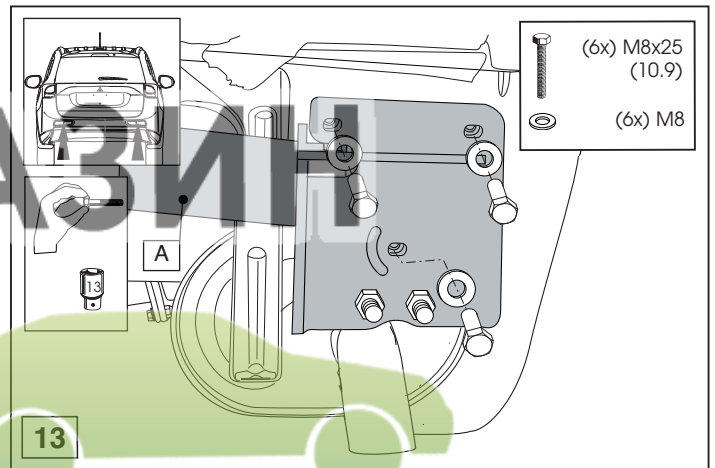
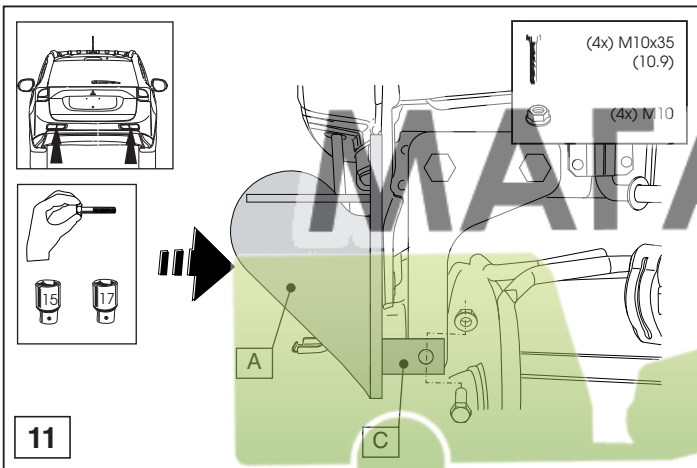
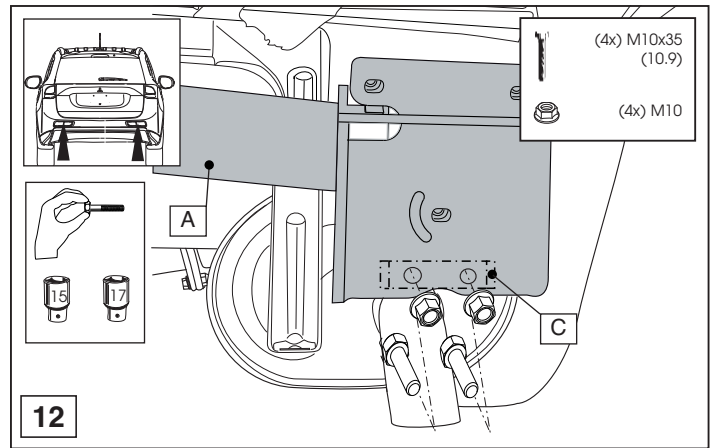
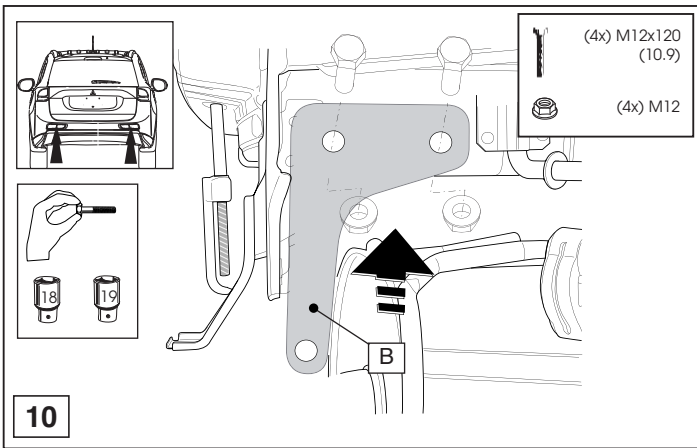

© 567970/31-10-2013/9

МАГАЗИН ФАРКОПОВ

+7 (495) 6-693-693

www.magfarkop.ru
magfarkop@yandex.ru

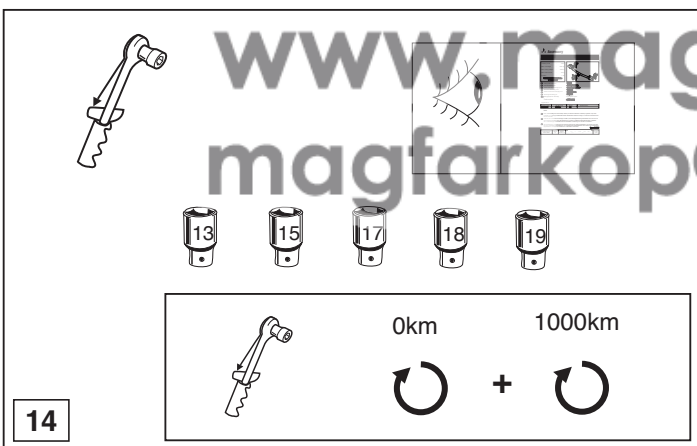

© 567970/31-10-2013/10

МАГАЗИН



ФАРКОПОВ

+7 (495) 6-693-693

www.magfarkop.ru

magfarkop@yandex.ru

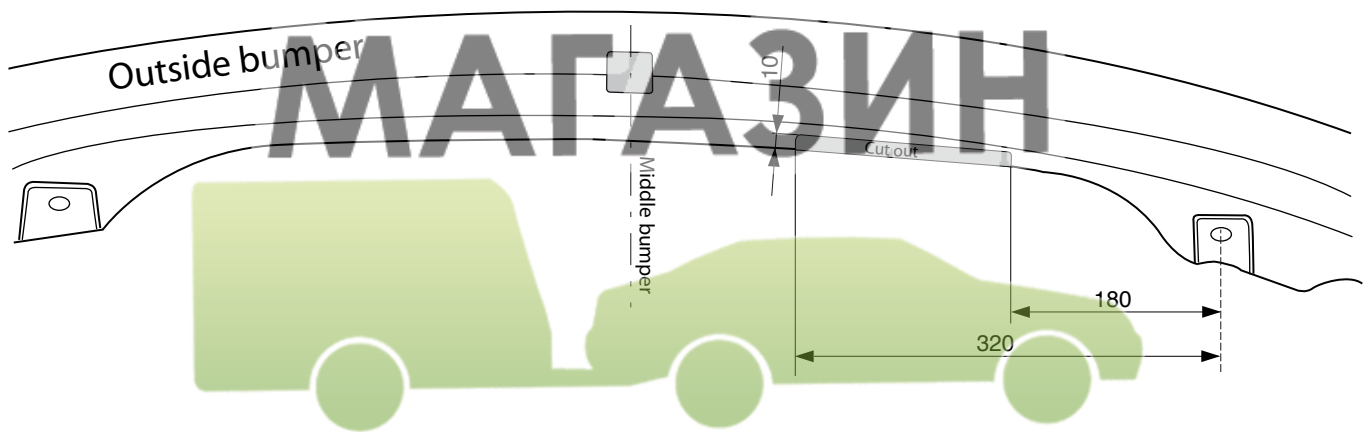

ФАРКОПОВ

+7 (495) 6-693-693

www.magfarkop.ru
magfarkop@yandex.ru

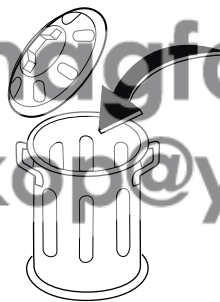

МАГАЗИН



ФАРКОПОВ

+7 (495) 6-693-693

www.magfarkop.ru

magfarkop@yandex.ru

Template 5679

Place on outside bumper

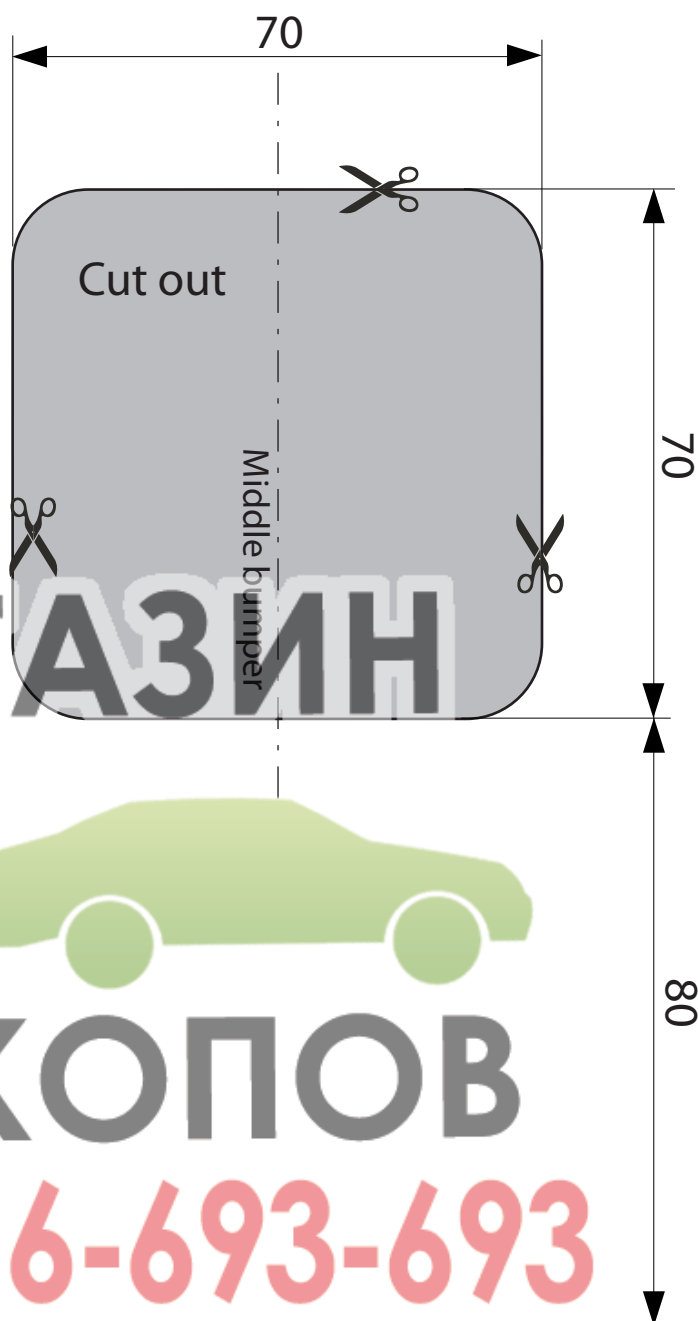

МАГАЗИН



ФАРКОПОВ

+7 (495) 6-693-693

www.magfarkop.ru
magfarkop@yandex.ru

Bumper

