

bosal

МАГАЗИН

**Инструкция
по монтажу тягово-сцепного
устройства шарового типа 4337 А
для автомобилей
Nissan X - Trail**



ФАРКОПОВ

+7 (495) 6-693-693

	2001/9– ...
	1500
	100
	20,9

www.magfarkop.ru
magfarkop@yandex.ru



462800,

18

т. (35363) 7-05-06
ф. (35363) 7-13-20
(495) 785-66-07
www.bosal-autoflex.ru

« - » (8182) 22-48-15
" 8(8442) 98-74-98
" 8(343) 379-39-89, 373-42-73
" 8(343) 26-88-308
" 8(3952) 710-194
" 8(495) 777-54-59
" 8(495) 745-79-11
" 8(495) 788-95-97
" 8(495) 720-51-03
" 8(3532) 57-99-85
" 8-905-899-5012
" 8(383) 291-59-60
" 8(831) 279-53-24
" 8(3422) 98-27-20
" 8(342) 220-87-87
" 8-927-002-90-06
" 8(3462) 24-00-44
" 8(3842) 21-14-76
" 8-902-940-4151
" 8(3452) 32-22-12, 41-52-62
" 8-961-213-0278
" 8-917-347-1700
" 8(351) 269-44-75, 900-72-73
" 8(3512) 773-76-91

МАГАЗИН



(2)

(1)

ФАРКОПОВ

+7 (495) 6-693-693

www.magfarkop.ru
magfarkop@yandex.ru

1		
2		
3		
4		
5		
6		
7		

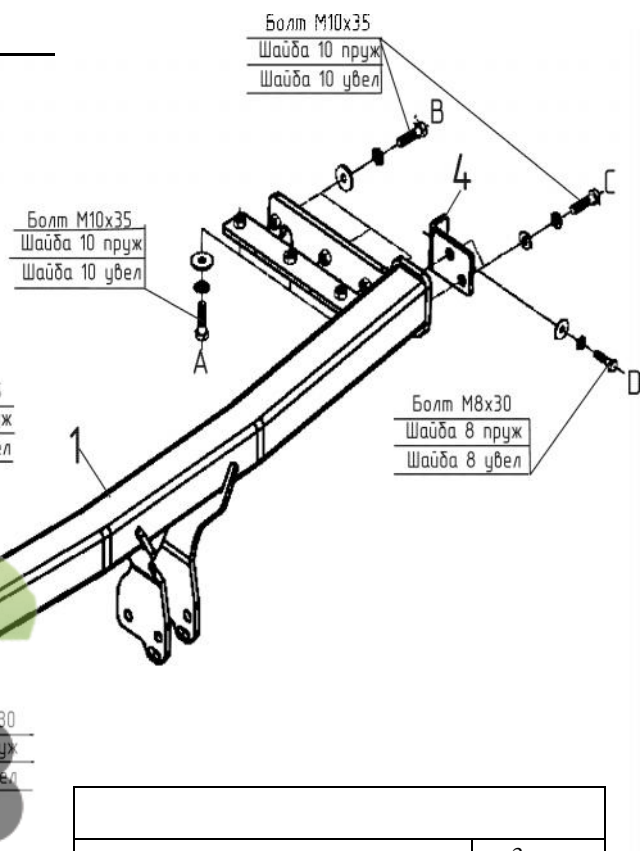

	3
8 30	2
10 35	17
12 1,25 90	2
12 1,25	2
8 (.)	2
8 (.)	2
10 (.)	17
10 (.)	17
12	4
	1
	1
	2
VH 0188	1
	1
	1
190	1
	1
	1