

bosal

МАГАЗИН

**Инструкция по монтажу
тягово-сцепного устройства
шарового типа 4221 А
для автомобилей
Hyundai Accent**

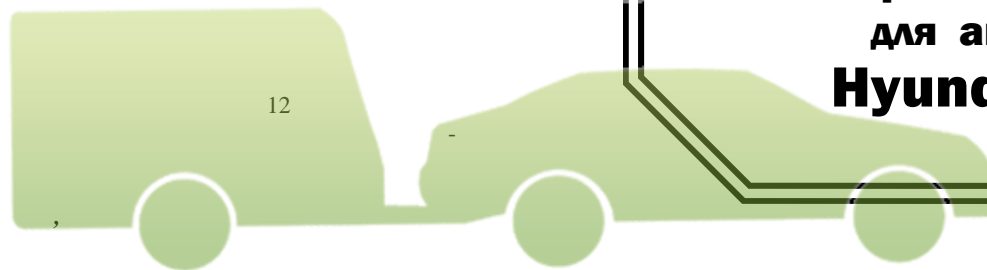

ФАРКОПОВ

+7 (495) 6-693-693

	2000/1-...
	1000
	75
	14,9

www.magfarkop.ru
magfarkop@yandex.ru

462800,

18

:(35363) 7-05-06

/(35363) 7-13-20

(495) 785-66-07

www.bosal-autoflex.ru

« - »	(8182) 22-48-15
" " " 8(8442) 98-74-98	" " " 8(343) 379-39-89, 373-42-73
" " " 8(343) 26-88-308	" " " 8(3952) 710-194
" " " 8(495) 777-54-59	" " " 8(495) 745-79-11
" " " 8(495) 788-95-97	" " " 8(495) 720-51-03
" " " 8(3532) 57-99-85	" " " 8-905-899-5012
" " " 8(383) 291-59-60	" " " 8(831) 279-53-24
" " " 8(3422) 98-27-20	" " " 8(342) 220-87-87
" " " 8-927-002-90-06	" " " 8(3462) 24-00-44
" " " 8(3842) 21-14-76	" " " 8-902-940-4151
" " " 8(3452) 32-22-12, 41-52-62	" " " 8-961-213-0278
" " " 8-917-347-1700	" " " 8(351) 269-44-75, 900-72-73
" " " 8(3512) 773-76-91	

41.55-2005.

МАГАЗИН



ФАРКОПОВ

+7 (495) 6-693-693

www.magfarkop.ru
magfarkop@yandex.ru

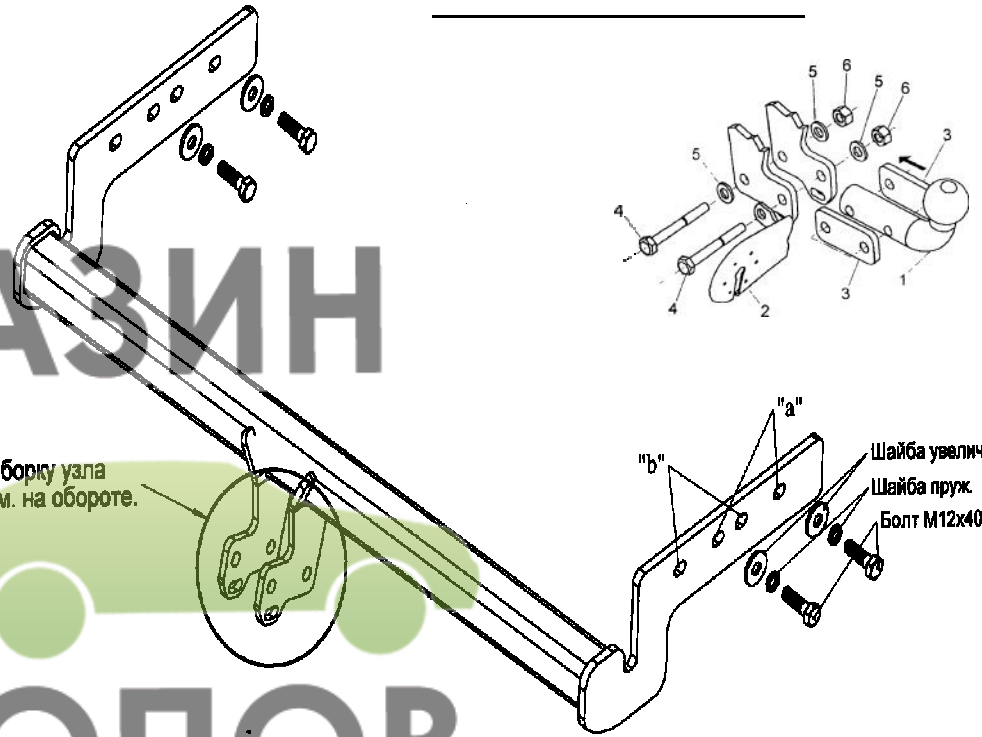

Схема обрезки кабеля

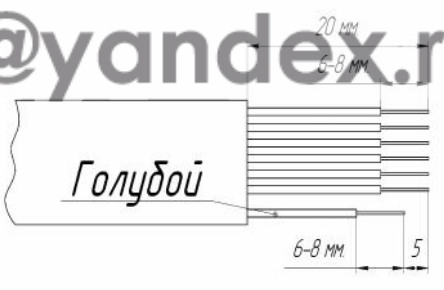

1		
2		
3		
4		
5		
6		
7		

		3
12 1,25 /		2
12		4
12		4
12		4
12 1,25 90		2
12 1,25 40		4
		2
VH 0208		1
		1
		1
		1
		1
	130	1
		1