

(,)

« »

: 12 = 79 Nm, 10 = 45 Nm.

МАГАЗИН

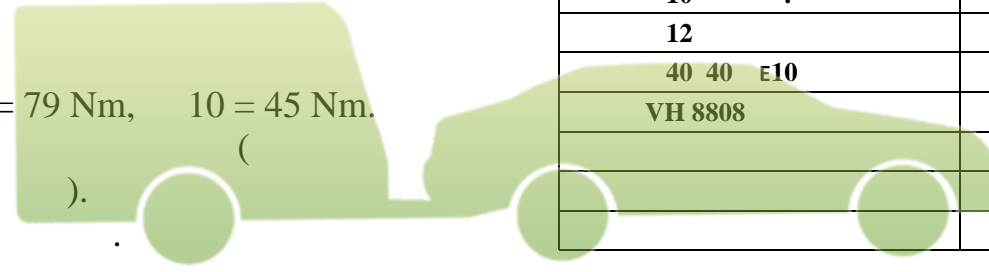

ФАРКОПОВ

+7 (495) 6-693-693

www.magfarkop.ru

magfarkop@yandex.ru

462800,

18

т. (35363) 7-05-06
ф. (35363) 7-13-20
(495) 799-13-46

www.bosal-autoflex.ru
www.bosal.com
info@bosal-autoflex.ru





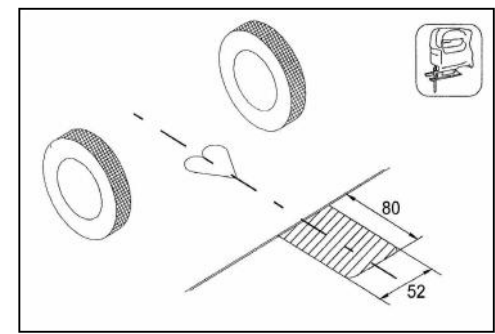





	1	1	.
12 50	4	.	.
10 40	4	.	.
12 1,25 75	2	.	.
12 1,25 /	2	.	.
10	4	.	.
12	4	.	.
12	4	.	.
10	4	.	.
12	4	.	.
40 40 E10	4	.	.
VH 8808	1	.	.
	1	.	.
	1	.	.
	1	.	.
	1	.	.



Момент затяжки	
M6	9,5 Nm
M8	23 Nm
M10	46 Nm
M12	79 Nm
M14	125 Nm
M16	195 Nm
M10x1,25	49 Nm
M12x1,25	87 Nm
M12x1,5	83 Nm

	1	.
	1	.
	1	.
	1	.
	1	.
	1	.

.....
.....	VIN
.....
.....

-	39 73 Ford Focus III Estate	 					D	
	 03/2011 →		3180	1200	75	19,2	8,54 kN.	Bosal Autoflex Russia BAR 28

МАГАЗИН



A

- Болт M10x40
- Шайба 10 (пружин)
- Шайба 10 (увелч.)
- Шайба 40x40

Балка ТСУ

Правый кронштейн



Левый кронштейн

- Болт M12x50
 - Шайба 12 (пруж.)
 - Шайба 12 (увелч.)
- B

- Болт M12x125x75
- Шайба 12
- Гайка M12x125 (с/контр.)

Шар

Подрозетник



+7 (495) 6-693-693

www.magfarkop.ru
magfarkop@yandex.ru

bosal