

**SIARR**

51 - 20



# NOTICE DE MONTAGE

**WESTFALIA**

342105600001

## MONTAGE

- \* Repérer les 4 trous existants "X" dans la traverse arrière.
- \* Insérer l'attelage dans la traverse aux points "X" à l'aide de l'ensemble visserie "X".

## FINITION

- \* Serrer l'ensemble aux couples indiqués ci-dessous.
- \* Monter la tête d'attelage et le support prise aux points "Y".

## BLOC VISSERIE

**X**

4 vis HM12x110  
4 écrous HM12  
4 rondelles plates 12,5/30  
4 rondelles DEC12

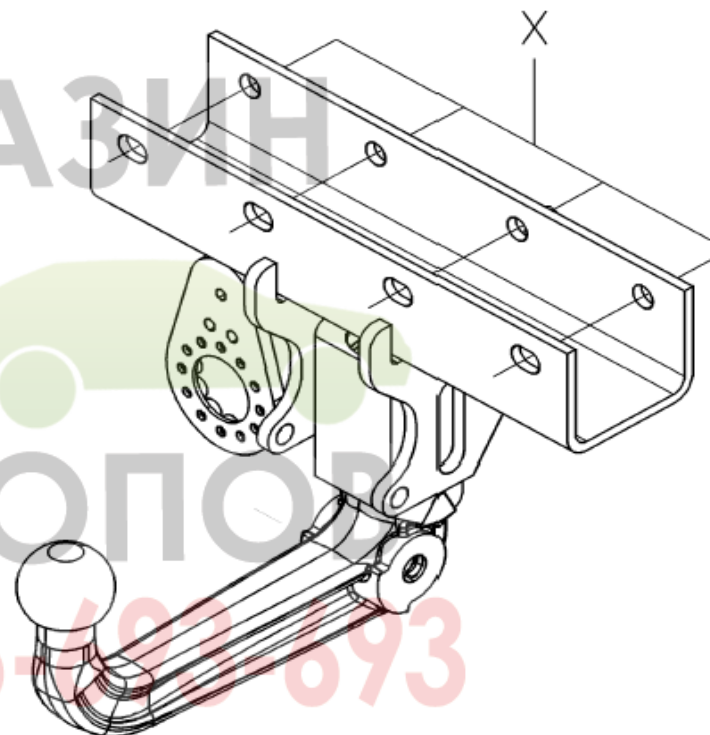

| Type<br>SI071  | Homologation<br>de Type n° | Poids Total<br>maxi autorisé | Poids Total<br>remorquable | Charge verti-<br>cale maxi | Valeur<br>D |
|--|----------------------------|------------------------------|----------------------------|----------------------------|-------------|
| Attelage pour<br>Chrysler Jeep Wrangler (Std)<br>Jeep unlimited overland (Std) | e24*94/20*0102*02          | 2 730 kg                     | 3 500 kg                   | 170 kg                     | 15,04 kN    |

**NOTA :** Schéma électrique à l'intérieur de nos faisceaux universels ou personnalisés.

### COUPLES DE SERRAGE :

|     |        |          |     |        |          |    |        |         |
|-----|--------|----------|-----|--------|----------|----|--------|---------|
| M16 | AC8.8  | 19,5daNm | M12 | AC10.9 | 11,4daNm | M8 | AC8.8  | 2,3daNm |
| M16 | AC10.9 | 27,5daNm | M10 | AC8.8  | 4,7daNm  | M8 | AC10.9 | 3,3daNm |
| M12 | AC8.8  | 8,1daNm  | M10 | AC10.9 | 6,7daNm  |    |        |         |

### ATTENTION : (pour connaître les caractéristiques d'utilisation consulter la carte grise)

Installé suivant nos recommandations, cet attelage vous donnera entière satisfaction.  
Nous dégageons toute responsabilité en cas de transformation ou d'utilisation illicite de celui-ci.

**SIARR**

51 - 20



# ASSEMBLY INSTRUCTIONS

**WESTFALIA**

342105600001

## ASSEMBLY

- \* Mark the 4 existing holes "X" in the rear cross-member.
- \* Insert the coupling in the cross-member at point "X" using bolting kit "X".

## FINISHING

- \* Tighten all of the nuts, bolts and screws to the torques indicated below.
- \* Fit the coupling head and socket support at point "Y".

## FASTENING KIT

- X**
- 4 HM12x110 screws
  - 4 HM12 nuts
  - 4 12,5/30 plain washers
  - 4 DEC12 washers

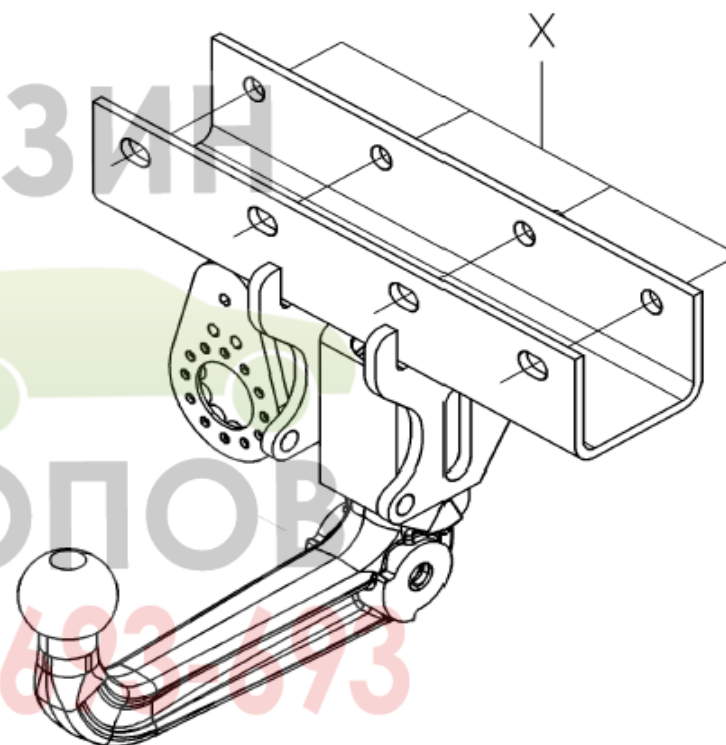

| Type<br>SI071                                   | Type<br>Approval No. | Max. Total<br>Authori. Weight | Max. Total<br>Towable Weight | Max. Verti-<br>cal load | Value<br>D |
|---|----------------------|-------------------------------|------------------------------|-------------------------|------------|
| Tow bar for<br>Chrysler Jeep<br>Wrangler (RDSO) | e24*94/20*0102*02    | 2 730 kg                      | 3 500 kg                     | 170 kg                  | 15,04 kN   |

**NB :** Electrical diagram inside our universal or custom wiring kits.

### TORQUES :

|     |        |          |     |        |          |    |        |         |
|-----|--------|----------|-----|--------|----------|----|--------|---------|
| M16 | AC8.8  | 19,5daNm | M12 | AC10.9 | 11,4daNm | M8 | AC8.8  | 2,3daNm |
| M16 | AC10.9 | 27,5daNm | M10 | AC8.8  | 4,7daNm  | M8 | AC10.9 | 3,3daNm |
| M12 | AC8.8  | 8,1daNm  | M10 | AC10.9 | 6,7daNm  |    |        |         |

**PLEASE NOTE :** (to familiarise yourself with the operating characteristics refer to the log)

If this tow bar is fitted in accordance with our recommendations it will give a complete satisfaction. We cannot accept any responsibility in the event of changes to or improper use of this item.

**SIARR**

51 - 20



# MONTÁŽNÍ POSTUP

**WESTFALIA**

34210560001

## MONTÁŽ

- \* V zadní příčce najdete 4 existující otvory „X“.
- \* Pomocí sady šroubů „X“ vsuňte tažné zařízení do příčky, do bodů „X“.

## DOKONČOVACÍ PRÁCE

- \* Utáhněte všechny šrouby na níže uvedené utahovací momenty.
- \* Namontujte hlavici závěsu pro přívěs a držák zásuvky do bodů „Y“.

## SADY ŠROUBŮ

- X**
- 4 šrouby HM12x110
  - 4 šroubů HM12
  - 4 ploché podložky 12,5/30
  - 4 podložky DEC12

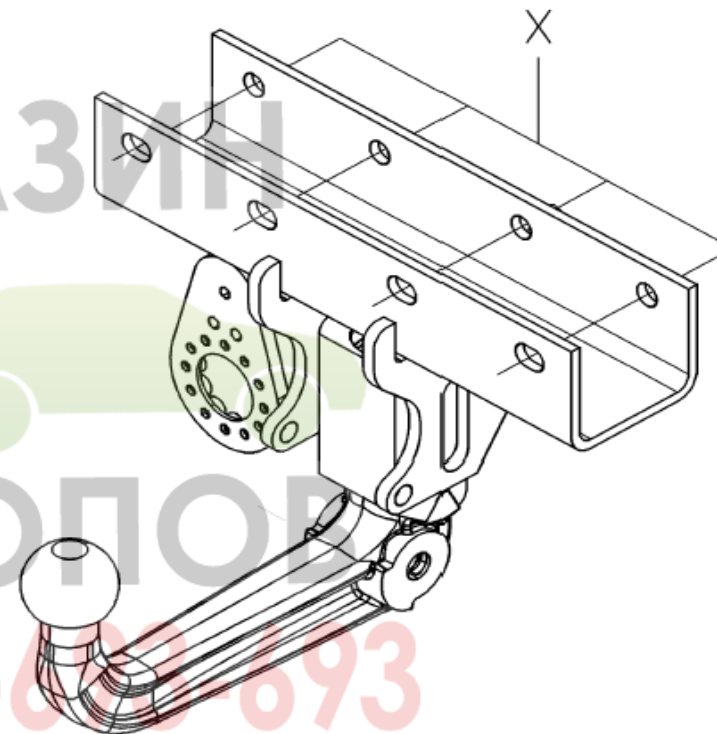

| Typ SI071  | Homologace Typu č. | Celková maximální povolená váha | Celková tažná hmotnost | Maximální vertikální zatížení | Hodnota D |
|--|--------------------|---------------------------------|------------------------|-------------------------------|-----------|
| Tažné zařízení pro Chrysler Jeep Wrangler (RDSO) | e24*94/20*0102*02  | 2 730 kg                        | 3 500 kg               | 170 kg                        | 15,04 kN  |

**POZNÁMKA:** Elektrické schéma univerzálních nebo na míru upravených svazků.

### UPÍNACÍ MOMENTY:

|     |        |          |     |        |          |    |        |         |
|-----|--------|----------|-----|--------|----------|----|--------|---------|
| M16 | AC8.8  | 19,5daNm | M12 | AC10.9 | 11,4daNm | M8 | AC8.8  | 2,3daNm |
| M16 | AC10.9 | 27,5daNm | M10 | AC8.8  | 4,7daNm  | M8 | AC10.9 | 3,3daNm |
| M12 | AC8.8  | 8,1daNm  | M10 | AC10.9 | 6,7daNm  |    |        |         |

### POZOR: (uživatelské charakteristiky naleznete v technickém průkazu)

Tažné zařízení instalované dle našich doporučení vás plně uspokojí.  
V případě přestavby nebo neoprávněného užívání se zbavujeme veškeré odpovědnosti

**SIARR**

51 - 20



# MONTERINGSVEJLEDNING

**WESTFALIA**

34210560001

## MONTERING

- \* Afmærk de 4 eksisterende huller "X" i bagtraversen.
- \* Indfør anhængertrækket i traversen ved punkterne "X" med befæstelserne "X".

## TIL SLUT

- \* Tilspænd befæstelserne med nedennævnte momenter.
- \* Monter kuglehovedet og holderen til stikket ved punkterne "Y".

## BEFÆSTELSER

- X**
- 4 bolte HM12x110
  - 4 møtrikker HM12
  - 4 flade skiver 12,5/30
  - 4 skiver DEC12

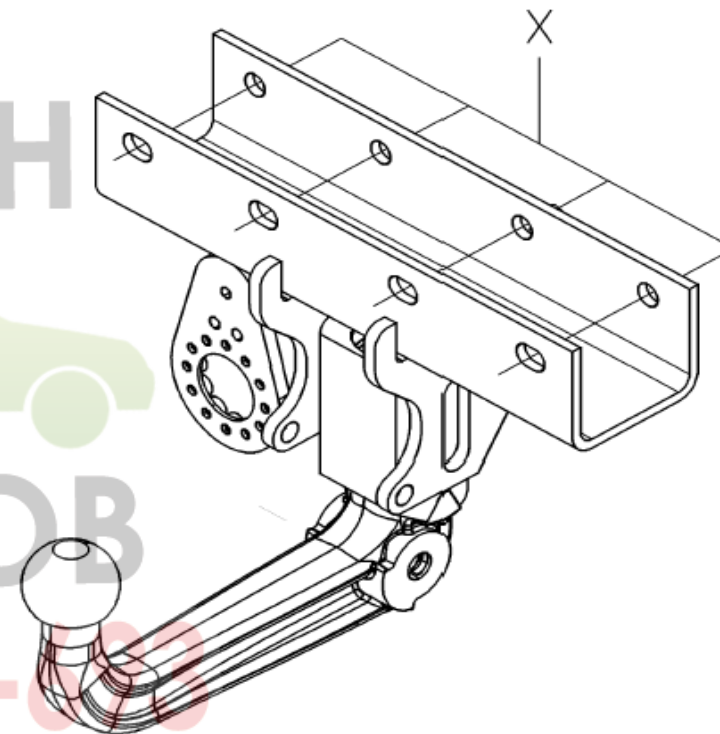

| Type<br>SI071  | Godkendt<br>typenr. | Totalvægt<br>maks. tilladt | Totalvægt<br>anhængervægt | Kugletryk<br>maks. | Værdi<br>D |
|--|---------------------|----------------------------|---------------------------|--------------------|------------|
| Anhængertræk til<br>Chrysler Jeep<br>Wrangler (RDSO) | e24*94/20*0102*02   | 2 730 kg                   | 3 500 kg                  | 170 kg             | 15,04 kN   |

**NB:** El-skema for vores universelle eller specielle ledningsnet.

### TILSPÆNDINGSMOMENT:

|     |        |          |     |        |          |    |        |         |
|-----|--------|----------|-----|--------|----------|----|--------|---------|
| M16 | AC8.8  | 19,5daNm | M12 | AC10.9 | 11,4daNm | M8 | AC8.8  | 2,3daNm |
| M16 | AC10.9 | 27,5daNm | M10 | AC8.8  | 4,7daNm  | M8 | AC10.9 | 3,3daNm |
| M12 | AC8.8  | 8,1daNm  | M10 | AC10.9 | 6,7daNm  |    |        |         |

**BEMÆRK:** (for yderligere oplysninger om anvendelsesforhold henvises der til registreringsattesten)

Hvis dette anhængertræk monteres i henhold til vores anvisninger, vil det være til din fulde tilfredshed. Vi fralægger os ethvert ansvar ved ulovlig ændring eller brug af anhængertrækket.

**SIARR**

51 - 20



# MONTAGEANLEITUNG

**WESTFALIA**

34210560001

## MONTAGE

- \* Kennzeichnen Sie die 4 Löcher « X » auf dem hinteren Querträger.
- \* Führen Sie die Kupplung mithilfe der Verschraubung « X » an den Punkten « X » ein.

## FERTIGSTELLUNG

- \* Ziehen Sie die gesamte Verschraubung mit den unten angegebenen Drehmomenten an.
- \* Montieren Sie den Kupplungskopf und die Steckerhalterung mithilfe der Verschraubung an den Punkten « Y ».

## SCHRAUBENSATZ

**X**

- 4 Schrauben HM12x110
- 4 Muttern HM12
- 4 flache Scheiben 12,5/30
- 4 Scheiben DEC12

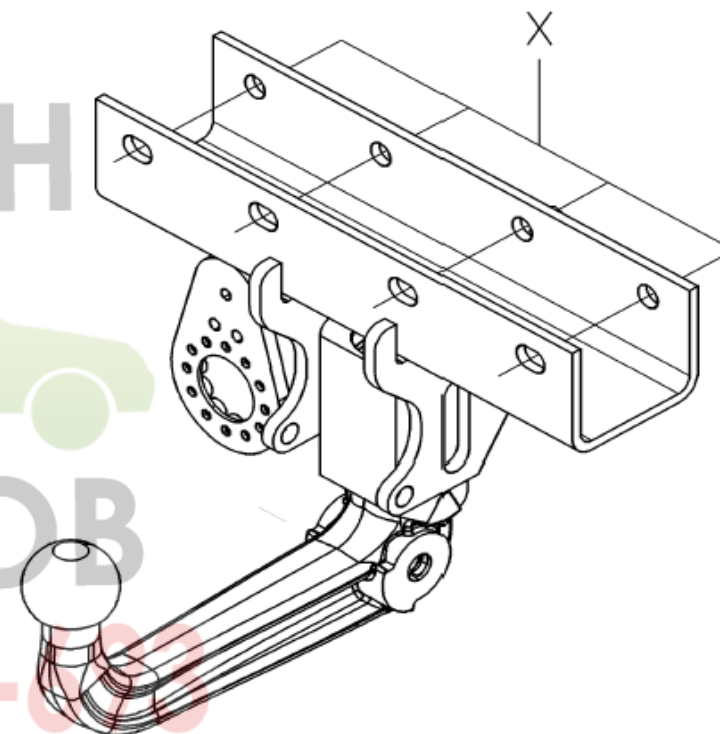

| Typ<br>SI071   | EG<br>Genehmigungs-Nr. | Maximal zulässiges<br>Gesamtgewicht | Maximal zulässiges<br>Anhängelast | Maximale<br>Stützlast | Max.<br>D-Wert |
|--|------------------------|-------------------------------------|-----------------------------------|-----------------------|----------------|
| Anhängevorrichtung<br>Chrysler Jeep<br>Wrangler (RDSO) | e24*94/20*0102*02      | 2 730 kg                            | 3 500 kg                          | 170 kg                | 15,04 kN       |

**HINWEIS:** Elektroschema liegt unseren (Universal - oder spezifische) Kabelsätzen bei.

### **ANZUGSDREHMOMENTE:**

|     |        |          |     |        |          |    |        |         |
|-----|--------|----------|-----|--------|----------|----|--------|---------|
| M16 | AC8.8  | 19,5daNm | M12 | AC10.9 | 11,4daNm | M8 | AC8.8  | 2,3daNm |
| M16 | AC10.9 | 27,5daNm | M10 | AC8.8  | 4,7daNm  | M8 | AC10.9 | 3,3daNm |
| M12 | AC8.8  | 8,1daNm  | M10 | AC10.9 | 6,7daNm  |    |        |         |

### **ACHTUNG: (Nutzungsmerkmale : siehe Fahrzeugschein)**

Diese Anhängevorrichtung wird Sie voll zufrieden stellen, wenn Sie unsere Montageanleitung befolgen.

Im Falle der unerlaubten Veränderung oder des unerlaubten Gebrauchs lehnen wir jede Haftung ab.

**SIARR**

51 - 20



# ΣΗΜΕΙΩΣΗ ΤΟΠΟΘΕΤΗΣΗΣ

**WESTFALIA**

342105600001

## ΤΟΠΟΘΕΤΗΣΗ

- \* Εντοπίστε τις 4 οπές « X » που υπάρχουν στην πίσω τραβέρσα .
- \* Εισαγάγετε το σύστημα ρυμούλκησης στην τραβέρσα στα σημεία « X » με τη βοήθεια του συνόλου των κοχλιών « X ».

## ΤΕΛΕΙΩΜΑ

- \* Σφίξτε όλες τις βίδες με τις ροπές στρέψης που αναφέρονται παρακάτω.
- \* Τοποθετήστε την κεφαλή του συστήματος ρυμούλκησης και τη βάση πρίζας στα σημεία « Y ».

## ΣΥΝΟΛΑ ΚΟΧΛΙΩΝ

|          |                         |
|----------|-------------------------|
| <b>X</b> | 4 βίδες HM12x110        |
|          | 4 περικόχλια HM12       |
|          | 4 ροδελες πλακέ 12,5/30 |
|          | 4 ροδέλε DEC12          |

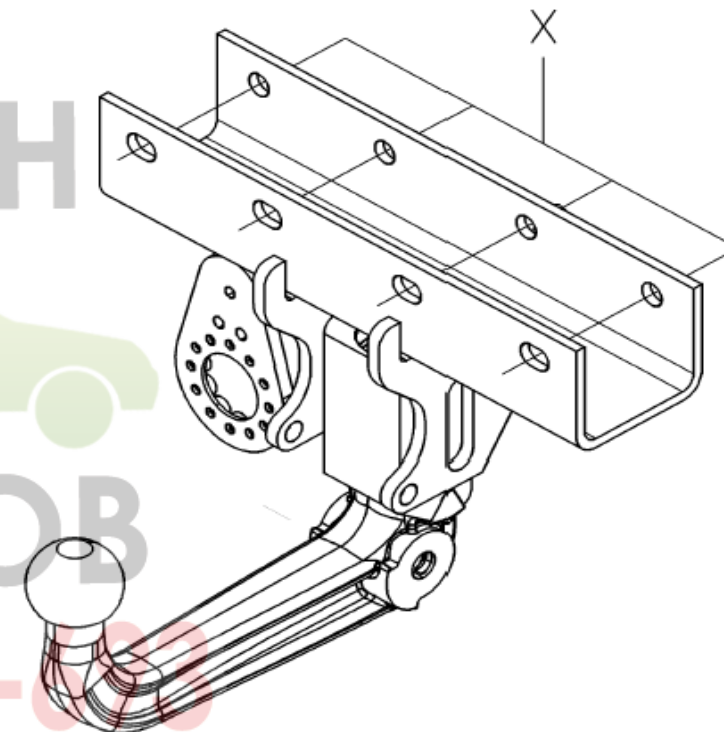

| Τύπος SI071   | Εγκριση Τύπου αριθ. | Ολικό Βάρος μέγ Επιτρεπόμενο | Ολικό Βάρος ρυμουλκίσιμο | Κατακόρυφο φορτίομέγ. | Τιμή D   |
|---|---------------------|------------------------------|--------------------------|-----------------------|----------|
| Σύστημα ρυμούλκησης για Chrysler Jeep Wrangler (RDSO) | e24*94/20*0102*02   | 2 730 kg                     | 3 500 kg                 | 170 kg                | 15,04 kN |

**ΣΗΜΕΙΩΣΗ :** Ηλεκτρικό κύκλωμα στο εσωτερικό των γενικής χρήσεως δεσμών μας ή προσωποποιημένων.

### **ΡΟΠΕΣ ΣΤΡΕΨΗΣ ΓΙΑ ΤΗΝ ΣΥΣΦΙΞΗ**

|     |        |          |     |        |          |    |        |         |
|-----|--------|----------|-----|--------|----------|----|--------|---------|
| M16 | AC8.8  | 19,5daNm | M12 | AC10.9 | 11,4daNm | M8 | AC8.8  | 2,3daNm |
| M16 | AC10.9 | 27,5daNm | M10 | AC8.8  | 4,7daNm  | M8 | AC10.9 | 3,3daNm |
| M12 | AC8.8  | 8,1daNm  | M10 | AC10.9 | 6,7daNm  |    |        |         |

**ΠΡΟΣΟΧΗ :** (για να πληροφορηθείτε τα χαρακτηριστικά χρήσης συμβουλευτείτε την γκριζα κάρτα)

Εγκατεστημένο σύμφωνα με τις συστάσεις μας, αυτό το σύστημα ρυμούλκησης θα σας ικανοποιήσει πλήρως.

Απεκδύομεθα πάσης ευθύνης σε περίπτωση μετατροπής ή παράνομης χρήσης αυτού.

**SIARR**

51 - 20



# MANUAL DE MONTAJE

**WESTFALIA**

34210560001

## MONTAJE

- \* Localizar los 4 orificios existentes “X” en la traviesa trasera.
- \* Introducir el ensamblaje en la traviesa, en los puntos “X” con la ayuda del conjunto de tornillos y pernos “X”.

## ACABADO

- \* Apretar el conjunto de tornillos y pernos a las parejas indicadas a continuación.
- \* Montar la cabeza de ensamblaje y el soporte de la toma en los puntos “Y”.

## BLOQUE TORNILLERÍA

|          |                            |
|----------|----------------------------|
| <b>X</b> | 4 tornillos HM12x110       |
|          | 4 tuercas HM12             |
|          | 4 arandelas planas 12,5/30 |
|          | 4 arandelas DEC12          |

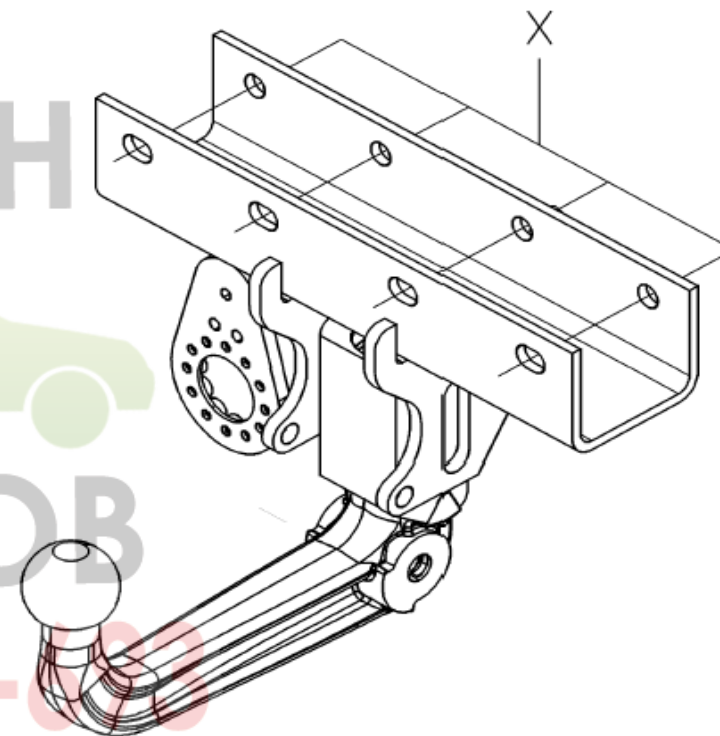

| Tipo<br>SI071                               | Homologación<br>de Tipo n° | Peso Total máximo autorizado | Peso Total remolcable | Carga vertical máxima | Valor D  |
|---|----------------------------|------------------------------|-----------------------|-----------------------|----------|
| Enganche para Chrysler Jeep Wrangler (RDSO) | e24*94/20*0102*02          | 2 730 kg                     | 3 500 kg              | 170 kg                | 15,04 kN |

**NOTA:** Esquema eléctrico en el interior de nuestros haces universales o personalizados.

### **PARES DE APRIETE:**

|     |        |          |     |        |          |    |        |         |
|-----|--------|----------|-----|--------|----------|----|--------|---------|
| M16 | AC8.8  | 19,5daNm | M12 | AC10.9 | 11,4daNm | M8 | AC8.8  | 2,3daNm |
| M16 | AC10.9 | 27,5daNm | M10 | AC8.8  | 4,7daNm  | M8 | AC10.9 | 3,3daNm |
| M12 | AC8.8  | 8,1daNm  | M10 | AC10.9 | 6,7daNm  |    |        |         |

### **ATENCIÓN:** (para conocer las características de utilización, consultar el permiso de circulación)

Instalado siguiendo nuestras recomendaciones, este enganche le dará total satisfacción. No asumiremos ninguna responsabilidad en caso de que haya sido transformado o utilizado ilícitamente

**SIARR**

51 - 20



# ASENNUSOHJEET

**WESTFALIA**
**34210560001**

## ASENNUS

- \* Etsi 4 valmista reikää « X » takapoikittaispalkissa.
- \* Laita vetokoukku poikittaispalkkiin pisteissä « X » ruuvien « X » avulla.

## VIIMEISTELY

- \* Kiristä ruuvit alla ilmoitetuilla momenteilla.
- \* Kiinnitä vetokoukun pää ja pistorasian tuki pisteisiin « Y ».

## KIINNITYSKOKONAISUUS

- X**
- 4 ruuvia HM12x110
  - 4 mutteria HM12
  - 4 litteää välilevyä 12,5/30
  - 4 välilevyä DEC12

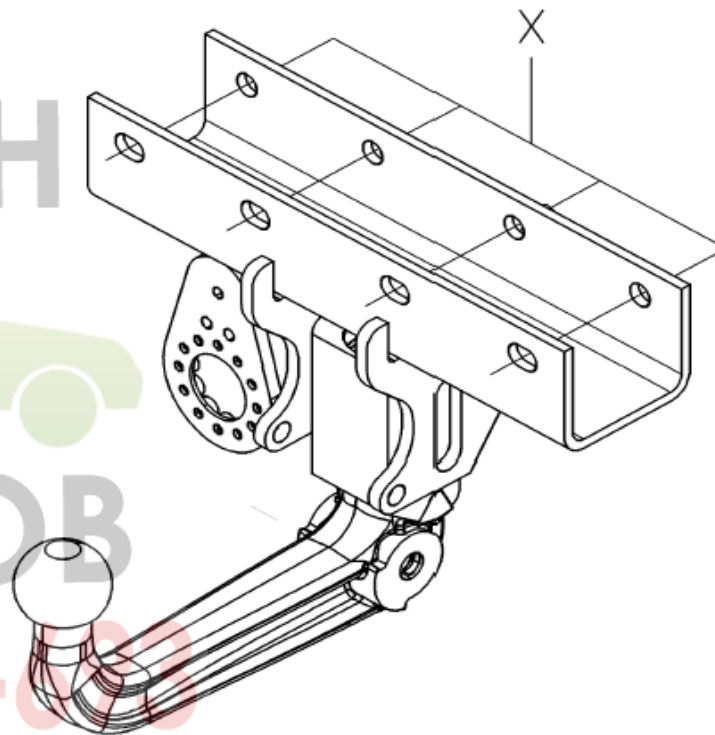

| Tyyppi<br>SI071                                | Tyyppihyväksyntä<br>Numero | Suuri sallittu<br>kokonaiskuorma | Vedettävissä oleva<br>kokonaispaino | Suurin sallittu<br>pystysuora rasitus | Arvo<br>D |
|--|----------------------------|----------------------------------|-------------------------------------|---------------------------------------|-----------|
| Vetokoukku<br>Chrysler Jeep<br>Wrangler (RDSO) | e24*94/20*0102*02          | 2 730 kg                         | 3 500 kg                            | 170 kg                                | 15,04 kN  |

**HUOM:** Sähköpiirros on yleisjohtojen tai yksilöllisten johtojen mukana.

### KIRISTYSMOMENTIT:

|     |        |          |     |        |          |    |        |         |
|-----|--------|----------|-----|--------|----------|----|--------|---------|
| M16 | AC8.8  | 19,5daNm | M12 | AC10.9 | 11,4daNm | M8 | AC8.8  | 2,3daNm |
| M16 | AC10.9 | 27,5daNm | M10 | AC8.8  | 4,7daNm  | M8 | AC10.9 | 3,3daNm |
| M12 | AC8.8  | 8,1daNm  | M10 | AC10.9 | 6,7daNm  |    |        |         |

**HUOMIO:** (käyttöominaisuuksiin tutustumiseksi on katsottava rekistreriotetta)

Suosittelun mukaan asennettuna tämä vetokoukku täyttää odotuksesi.  
Emme ota vastuuta, jos laitetta muutetaan tai käytetään ohjeiden vastaisesti.



**SIARR**

51 - 20



## AVVERTENZE PER IL MONTAGGIO

**WESTFALIA**

34210560001

### MONTAGGIO

- \* Individuare i 4 fori esistenti « X » sulla traversa posteriore.
- \* Inserire il gancio di traino sulla traversa nei punti « X » per mezzo del gruppo viteria « X ».

### RIFINITURA

- \* Stringere il gruppo viteria alle coppie qui di seguito indicate.
- \* Montare la testa del gancio di traino e il supporto presa nei punti « Y ».

### BLOCCO VITERIA

**X** | 4 viti HM12x110  
 4 dadi HM12  
 4 rondelle piatte 12,5/30  
 4 rondelle DEC12

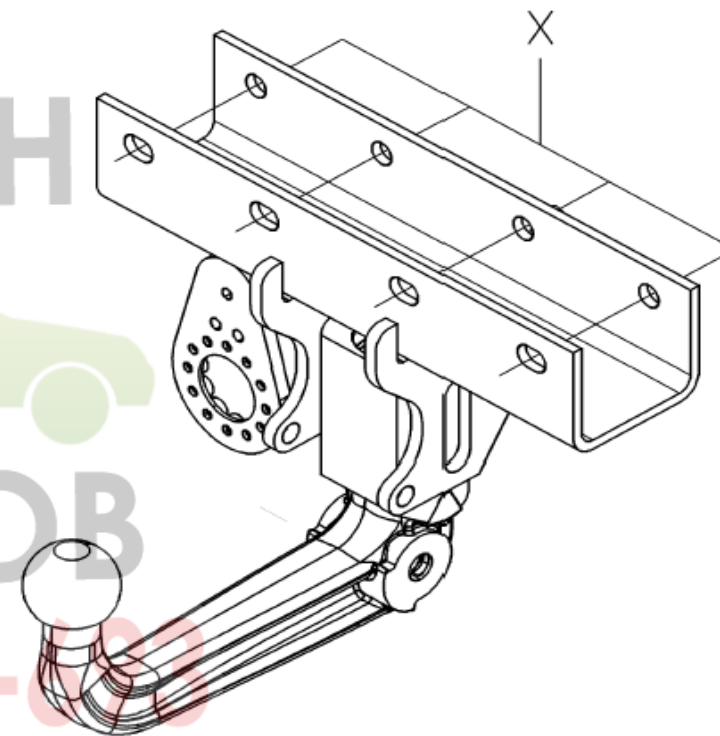

| Tipo<br>SI071                                      | Omologazione<br>di Tipo n° | Peso totale massimo autorizzato | Peso totale Rimorchiabile | Carico verticale massimo | Valore D |
|--|----------------------------|---------------------------------|---------------------------|--------------------------|----------|
| Gancio da traino per Chrysler Jeep Wrangler (RDSO) | e24*94/20*0102*02          | 2 730 kg                        | 3 500 kg                  | 170 kg                   | 15,04 kN |

**NOTA :** Schema elettrico all'interno dei nostri fasci universali o personalizzati.

### **COPPIE DI SERRAGGIO :**

|     |        |          |     |        |          |    |        |         |
|-----|--------|----------|-----|--------|----------|----|--------|---------|
| M16 | AC8.8  | 19,5daNm | M12 | AC10.9 | 11,4daNm | M8 | AC8.8  | 2,3daNm |
| M16 | AC10.9 | 27,5daNm | M10 | AC8.8  | 4,7daNm  | M8 | AC10.9 | 3,3daNm |
| M12 | AC8.8  | 8,1daNm  | M10 | AC10.9 | 6,7daNm  |    |        |         |

### **ATTENZIONE :** (per conoscere le caratteristiche d'uso consultare il libretto di circolazione)

Installato seguendo le nostre raccomandazioni, questo gancio da traino vi lascerà completamente soddisfatti.  
 Respingiamo ogni responsabilità in caso di trasformazione o utilizzo illecito dello stesso.

**MONTAGE**

- \* Markeer de 4 bestaande openingen in de achterdwarsbalk met « X ».
- \* Voeg de koppeling in de dwarsbalk in aan de punten « X » met behulp van het schroefwerk « X ».

**AFWERKING**

- \* Zet het geheel van het schroefwerk vast op de hieronder aangegeven koppels.
- \* Monteer de koppelingskop en de contactdrager aan de punten « Y ».

**SCHROEFBLOK**

**X** | 4 schroeven HM12x110  
 4 moeren HM12  
 4 drukplaten 12,5/30  
 4 ringen DEC12

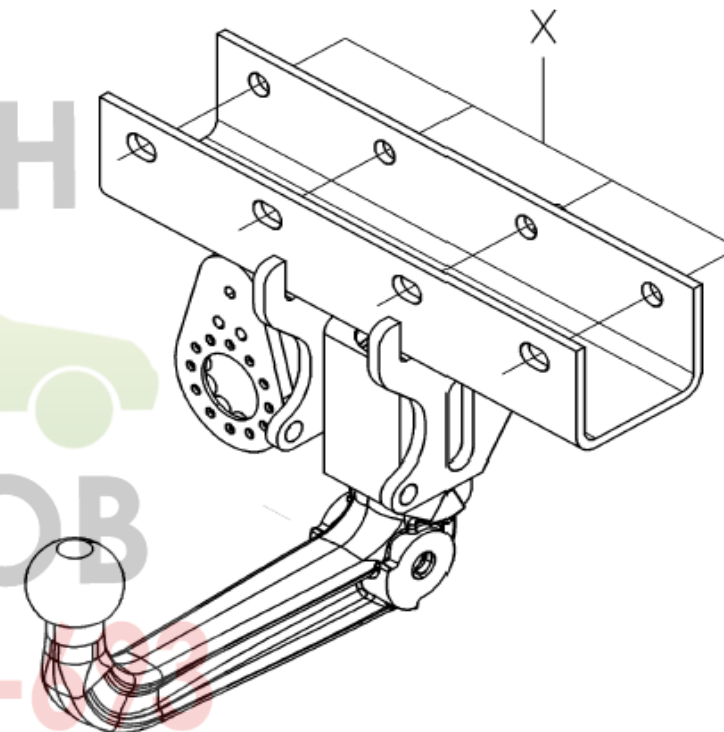

| Type<br>SI071                                      | Goedkeuring<br>Type n° | Max. toegestaan<br>totaalgewicht | Totaal<br>laadgewicht | Max. verticale<br>belasting | Waarde<br>D |
|--|------------------------|----------------------------------|-----------------------|-----------------------------|-------------|
| Koppeling voor<br>Chrysler Jeep<br>Wrangler (RDSO) | e24*94/20*0102*02      | 2 730 kg                         | 3 500 kg              | 170 kg                      | 15,04 kN    |

**NOTA BENE:** Bedradingsschema aan binnenkant van onze universele bundels of gepersonaliseerd.

**AANDRAAIMOMENTEN:**

|     |        |          |     |        |          |    |        |         |
|-----|--------|----------|-----|--------|----------|----|--------|---------|
| M16 | AC8.8  | 19,5daNm | M12 | AC10.9 | 11,4daNm | M8 | AC8.8  | 2,3daNm |
| M16 | AC10.9 | 27,5daNm | M10 | AC8.8  | 4,7daNm  | M8 | AC10.9 | 3,3daNm |
| M12 | AC8.8  | 8,1daNm  | M10 | AC10.9 | 6,7daNm  |    |        |         |

**LET OP: (voor gebruikskennmerken het kentekenbewijs raadplegen)**

Indien u de koppeling volgens onze aanbevelingen heeft geïnstalleerd, zal het u tot volle tevredenheid stemmen. Wij stellen ons niet aansprakelijk in geval van wijziging of onrechtmatig gebruik.

**SIARR**

51 - 20



# MONTERINGSVEILEDNING

**WESTFALIA**

34210560001

## MONTERING

- \* Merk av de 4 eksisterende hullene "X" i den bakre tverrbjelken.
- \* Sett hengerfestet inn i tverrbjelken i punktene "X" ved hjelp av skruesettet "X".

## ENDELIG UTFØRING

- \* Skru til alle skruene ved punktene som vist nedenfor.
- \* Monter kroken for hengerfestet og holderen for kontakten i punktene "Y".

## SKRUESETT

- X**
- 4 skruer HM12x110
  - 4 muttere HM12
  - 4 tetningsskiver 12,5/30
  - 4 skiver DEC12

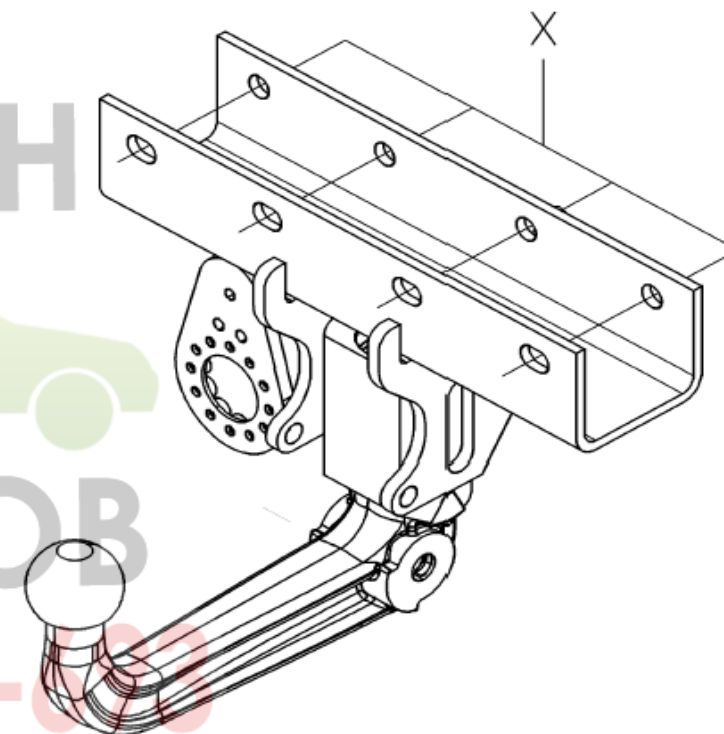

| Type<br>SI071  | Homologering<br>type nr. | Total vekt<br>maks. godkjent | Total vekt mu-<br>lig med tilhenger | Totalvekt tilhenger<br>maks. avstand | Verdi<br>D |
|--|--------------------------|------------------------------|-------------------------------------|--------------------------------------|------------|
| Tilhengerfeste til<br>Chrysler Jeep<br>Wrangler (RDSO) | e24*94/20*0102*02        | 2 730 kg                     | 3 500 kg                            | 170 kg                               | 15,04 kN   |

**MERKNAD:** Elektrisk skjema finnes i våre generelle eller personliggjorte brosjyrer.

### DREININGSMOMENTER:

|     |        |          |     |        |          |    |        |         |
|-----|--------|----------|-----|--------|----------|----|--------|---------|
| M16 | AC8.8  | 19,5daNm | M12 | AC10.9 | 11,4daNm | M8 | AC8.8  | 2,3daNm |
| M16 | AC10.9 | 27,5daNm | M10 | AC8.8  | 4,7daNm  | M8 | AC10.9 | 3,3daNm |
| M12 | AC8.8  | 8,1daNm  | M10 | AC10.9 | 6,7daNm  |    |        |         |

### ADVARSEL: (for kunnskap om bruksegenskapene, se vognkortet)

Ved å installere innretningen i samsvar med våre anbefalinger vil du få maksimalt utbytte av dette tilhengerfestet.

Vi fraskriver oss alt ansvar hvis tilhengerfestet endres eller brukes på ulovlig måte.

**SIARR**

51 - 20



# INSTRUKCJA MONTAŻU

**WESTFALIA**

34210560001

## MONTAŻ

- \* Odszukać 4 istniejące otwory „X” w tylnej poprzecznej listwie.
- \* Wsunąć dyszel w poprzeczną listwę w punktach « X », za pomocą zestawu śrub « X ».

## WYKOŃCZENIE

- \* Dokręcić wszystkie śruby zgodnie z momentami dokręcenia oznaczonymi poniżej.
- \* Zamontować czoło dyszla i wspornik w punktach « Y ».

## ZESTAW ŚRUB

- X**
- 4 śruby HM12x110
  - 4 nakładki HM12
  - 4 płaskie podkładki okrągłe 12,5/30
  - 4 okrągłych podkładkach DEC12

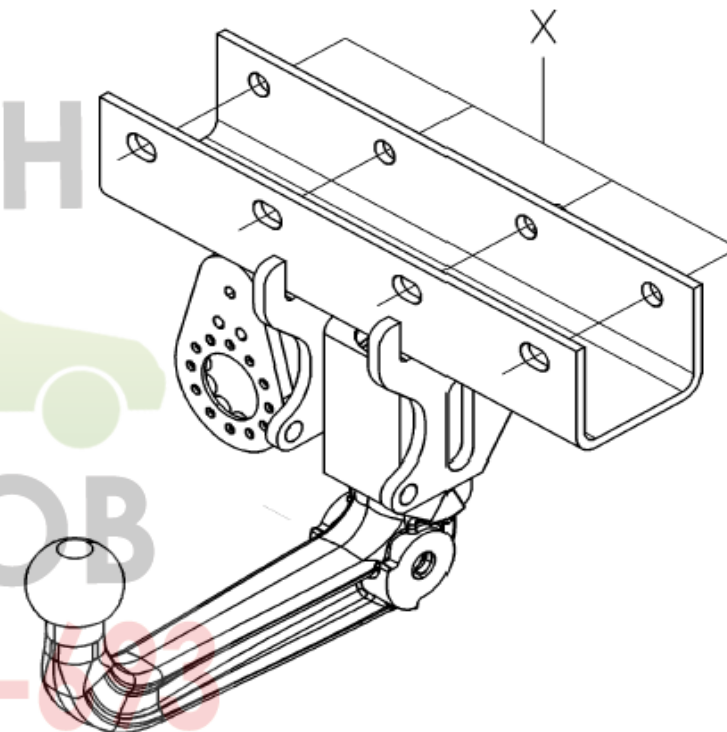

| Typ SI071  | Homologacja typu nr | Ciężar całkowity<br><small>holowania / dopuszczalny</small> | Ciężar całkowity<br><small>holowania / dopuszczalny</small> | Maksymalne obciążenie pionowe | Wartość D |
|--|---------------------|---|---|-------------------------------|-----------|
| Dyszel holowniczy do Chrysler Jeep Wrangler (RDSO) | e24*94/20*0102*02   | 2 730 kg  | 3 500 kg  | 170 kg                        | 15,04 kN  |

**Uwaga:** schemat elektryczny dołączony do wiązki podłączeniowej uniwersalnej lub specjalnej

### MOMENTY DOKRĘCENIA

|     |        |          |     |        |          |    |        |         |
|-----|--------|----------|-----|--------|----------|----|--------|---------|
| M16 | AC8.8  | 19,5daNm | M12 | AC10.9 | 11,4daNm | M8 | AC8.8  | 2,3daNm |
| M16 | AC10.9 | 27,5daNm | M10 | AC8.8  | 4,7daNm  | M8 | AC10.9 | 3,3daNm |
| M12 | AC8.8  | 8,1daNm  | M10 | AC10.9 | 6,7daNm  |    |        |         |

### UWAGA (charakterystyki użytkowania należy sprawdzić w dowodzie rejestracyjnym)

Dyszel holowniczy będzie funkcjonował we właściwy sposób po zainstalowaniu go zgodnie z zaleceniami.  
Nie ponosimy żadnej odpowiedzialności w przypadku wprowadzenia zmian lub niedozwolonego użycia

**SIARR**

51 - 20



# MONTERINGSANVISNING

**WESTFALIA**

34210560001

## MONTERING

- \* Hitta de 4 befintliga hålen "X" på den bakre tvärbalken.
- \* För in dragkroken i tvärbalken vid punkterna "X" med hjälp av skruvsatsen "X".

## SLUTLIGEN

- \* Skruva åt alla skruvar med nedanstående vridmoment.
- \* Montera dragkrokens huvud och stödfästet vid punkterna "Y".

## SKRUVBLOCK

- X**
- 4 skruvar HM12x110
  - 4 muttrar HM12
  - 4 rundbrickor 12,5/30
  - 4 fjäderbrickor DEC12

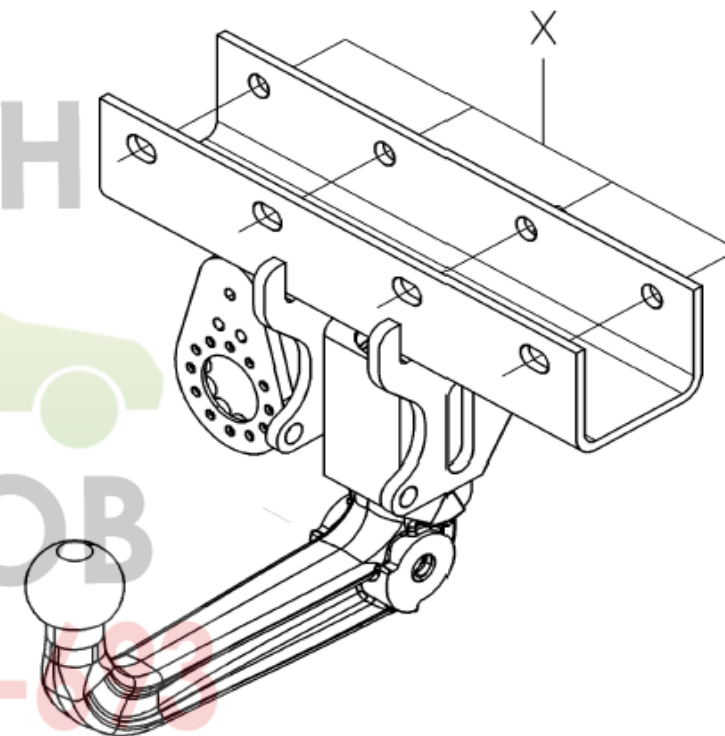

| Typexemplar<br>SI071                             | Typgodkännande<br>Av typexemplar n° | Totalvikt<br>Maxi-vikt | Totalvikt<br>bogserbar | Vertikal<br>maxi-vikt | Värde<br>D |
|--|-------------------------------------|------------------------|------------------------|-----------------------|------------|
| Montering av<br>Chrysler Jeep<br>Wrangler (RDSO) | e24*94/20*0102*02                   | 2 730 kg               | 3 500 kg               | 170 kg                | 15,04 kN   |

**Observera:** Elektriskt schema finns i våra allmänna eller mer specialiserade anvisningar

### VRIDMOMENT:

|     |        |          |     |        |          |    |        |         |
|-----|--------|----------|-----|--------|----------|----|--------|---------|
| M16 | AC8.8  | 19,5daNm | M12 | AC10.9 | 11,4daNm | M8 | AC8.8  | 2,3daNm |
| M16 | AC10.9 | 27,5daNm | M10 | AC8.8  | 4,7daNm  | M8 | AC10.9 | 3,3daNm |
| M12 | AC8.8  | 8,1daNm  | M10 | AC10.9 | 6,7daNm  |    |        |         |

### VARNING: (Läs igenom det grå bladet för att ta reda på rådande användningsvillkor)

Om du monterar produkten enligt våra anvisningar kommer du uppnå bästa möjliga resultat  
Vi avsäger oss allt ansvar i de fall kunden inte följt våra anvisningar fullt ut.

Dispositivo di traino tipo : **51 - 20**  
Per autoveicolo : **Chrysler Jeep Wrangler (RDSO)**  
Tipo funzionale : **JK ????? ??**

**WESTFALIA**

*Monoflex*



Classe e tipo di attacco : **A50-X**  
Omologazione : **e24\*94/20\*0102\*02**  
Valore D : **15,04 kN**  
Carico verticale max. S : **170 kg**  
Massa rimorchiabile : **vedi carta di circolazione dell'autoveicolo**

In base alla Direttiva europea 94/20, la massa massima rimorchiabile del dispositivo di traino è determinata dal valore di prova "D" così definito :

$$D = (T \times C) / (T + C) \times 0,00981 = 10,22 \text{ kN}$$

dove : T = Massa complessiva max. della motrice (in kg) e C = Massa rimorchiabile max. della motrice (in kg)

**DICHIARAZIONE DI CORRETTO MONTAGGIO :**

la sottoscritta Ditta dichiara che il dispositivo di traino tipo \_\_\_\_\_ è stato installato a regola d'arte, nel rispetto dei punti d'attacco e delle prescrizioni fornite dalla Casa costruttrice

sul veicolo \_\_\_\_\_

targato \_\_\_\_\_

li

Si dichiara inoltre di aver informato l'utente del veicolo sull'USO e MANUTENZIONE del dispositivo stesso.

timbro et firma

